



Optimal Solutions for the Future

FM *linear* series



**Ultra-high-speed,
High-precision
Vertical Machining
Center Equipped
with Linear Motors**

FM *linear* series

FM 200/5AX *linear*

FM 350/5AX *linear*

FM 400 *linear*

ver. EN 160502 SU



reddot award 2015
winner

Basic Information

Basic Structure
Travel Axis

Detailed
Information

Options
Capacity Diagram
Specifications

Customer Support
Service



FM *linear* series

The FM Linear Series offers super-fast traveling and great reliability with its high-speed spindle and linear axes driven by linear motors, in addition to excellent stability in cutting operation due to the adoption of anti-vibration materials.

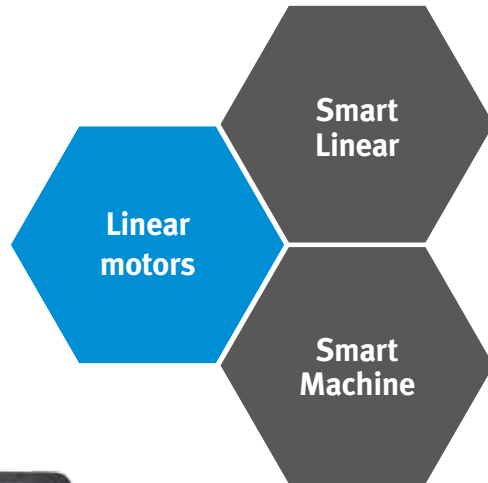

Contents

02 Product Overview

Basic Information

04 Basic Structure

04 Travel Axis

Detailed Information

06 Standard / Optional Specifications

09 Capacity Diagram

12 Machine / NC Unit Specifications

14 Customer Support Service

Sample work

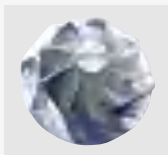

Stable bed and structure design

Stable cutting based on anti-vibration materials and symmetrical gantry structure.

Stable cutting based on anti-vibration materials and symmetrical gantry structure.

Outstanding productivity and cutting accuracy are delivered with 40,000 rpm spindles, linear motors, and direct-drive motors.

Heidenhain controller for maximum reliability

The adoption of Heidenhain controllers optimized for high-speed processing enhances machine reliability, visibility, and display applicability.

Basic Information

Basic Structure
Travel Axis

Detailed Information

Options
Capacity Diagram
Specifications

Customer Support Service

Basic Structure

Stable cutting based on symmetrical gantry structure and anti-vibration materials (mineral casting).

Structural and Material Features

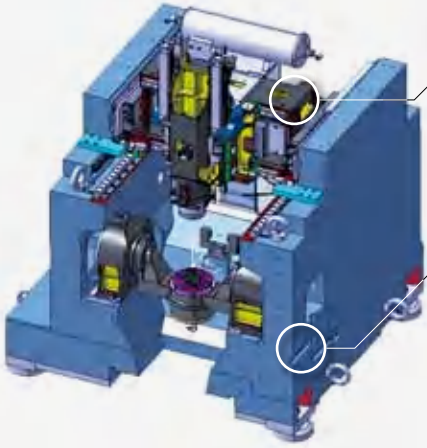

Gantry structure
Horizontally-symmetrical structure suitable for high-speed, high-precision machining
Guaranteed structural stability

Built with a mineral cast bed for stable performance



Built with a mineral cast bed for stable performance

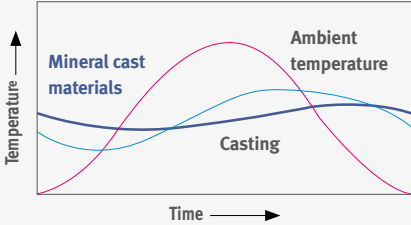

Normal cast materials
Mineral cast materials

↑ 25 times
Thermal stability 25 times greater

Axis System

The linear axes and rotary axes deliver high speed and superior accuracy.

Linear Axes Equipped with Linear Motors

The X / Y / Z linear axes are driven by linear motors to realize high speed and accuracy, as well as superior positioning and repeatability.

Up to **2G**

Description			FM 200/5AX linear	FM 350/5AX linear FM 400 linear
Rapid	X / Y / Z	m/min (ipm)	50 / 50 / 50 (1968.5 / 1968.5 / 1968.5)	80 / 80 / 80 (3149.6 / 3149.6 / 3149.6)
		Acc. / Deceleration	m/sec ²	14.7 / 14.7 / 14.7 [1.5G / 1.5G / 1.5G]



Rotary Axes Equipped with Direct Drive Motors*

The rotary table is equipped with a direct drive motor for rapid rotation coupled with rapid acceleration and deceleration. Thermal error is minimized by the water cooling system.

Description		Unit	FM 200/5AX linear	FM 350/5AX linear
Rapid	A / C	r/min	100 / 200	50 / 100
Travel		deg	140 / 360	240 / 360
Load Capacity		kg (lb)	15 (33.1)	100 (220.5)

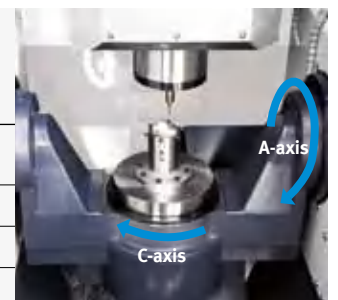

* For 5 axes only.

Spindle

The spindle provides incomparably high productivity and machining accuracy.

Ultra-high-speed Spindle

One of the highest-speed spindles in its class, the ultra-high-speed enhances productivity and machining accuracy.

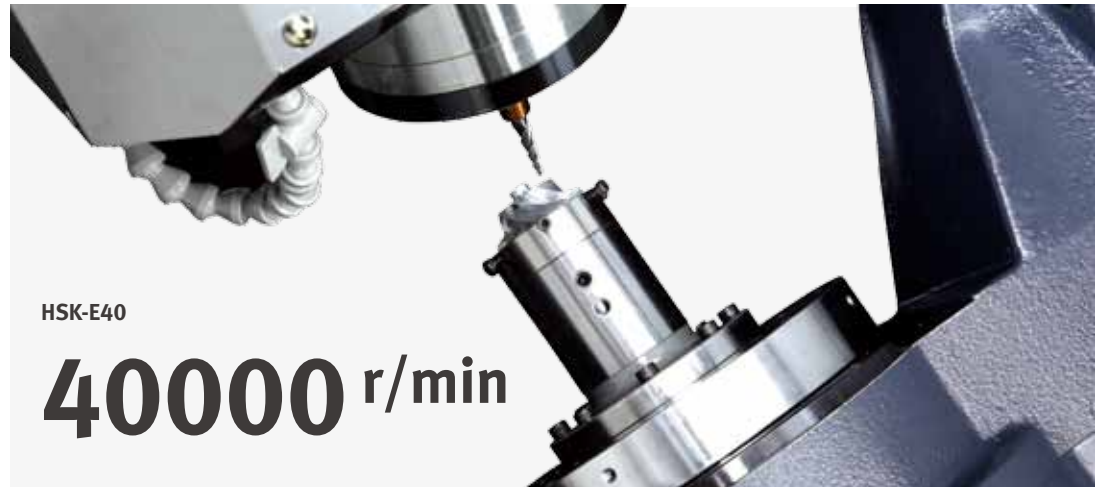

HEIDENHAIN

Spindle Speed : 40000 r/min
Spindle Motor : 12.6 kW (16.9 Hp)

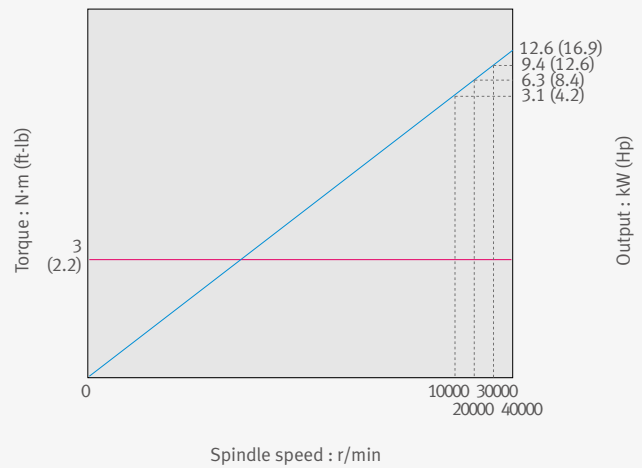

Magazine

The machine's structure has been simplified with the addition of a direct-drive motor, while the operator's convenience has been enhanced by manual magazine operation for tool storage.

Tool Magazine

Description	Unit	FM 200/5AX linear		FM 350/5AX linear FM 400 linear	
		No.	Max tool diameter	No.	Max tool length
No.	ea	24	50 (2.0)	40	180 (7.1)
Max tool diameter	mm (inch)				
Max tool length	mm (inch)				
Tool change time	s	8		10	

* FM 200/5AX model

Basic Information

Basic Structure
Travel Axis

Detailed Information

Options
Capacity Diagram
Specifications

Customer Support Service



Standard / Optional Specifications

Diverse optional features are available for customer-specific requirements.

● Standard ○ Optional X N/A

NO.	Description	Features	FM 200/5AX linear	FM 350/5AX linear	FM 400 linear
1	Tool magazine	24 tools	●	X	X
2		40 tools	X	●	●
3	Tool shank type	HSK-E40	●	●	●
4	Auto door lock		●	●	●
5	Rotary table	Ø200	●	X	X
6		Ø350	X	●	X
7	Linear scale	X-axis	●	●	●
8		Y-axis	●	●	●
9		Z-axis	●	●	●
10	Spindle	40000 r/min	●	●	●
11		Spindle head cooling system	●	●	●
12		Thermal error compensation system	●	●	●
13	Spindle motor power	12.6 kW (HEIDENHAIN)	●	●	●
14	Auto tool measuring device	NT-2_BLUM	●	●	●
15	Auto work measuring device	OMP400_RENISHAW (W/Receiver)	○	○	○
16		OMI-2C_RENISHAW (Receiver Only)	○	○	○
17	Master tool for auto tool measurement	CALIBRATION TOOL_BLUM (HSK E40)	○	○	○
18	Auto power cut-off		○	○	○
19	Coolant	FLOOD (0.7kW_0.8MPa)	●	X	X
20		FLOOD (1.5 kW_0.69MPa)	X	●	●
21		SHOWER	○	○	○
22	Chip bucket		○	○	○
23	Chip conveyor	Chip pan	●	●	●
24		Hinged type	X	○	○
25		Drum type	○	X	X
26	Table	500 x 600 mm	X	X	●
27	Test bar		○	○	○
28	AIR	AIR BLOWER	●	●	●
29	MPG	Portable MPG	●	●	●
30	MQL		○	○	○
31	NC system	HEIDENHAIN iTNC530	●	●	●
32	OIL SKIMMER	BELT TYPE	○	X	X
33		TUBE TYPE	X	○	○

Standard / Optional Specifications

Diverse options for enhanced work efficiency and operator convenience.

Convenient operation panel

The ergonomically-designed Heidenhain operation panel and 19-inch large screen enhance the operator's convenience



Tool length measurement device

The standard tool length laser measuring device secures the highest degree of accuracy even at super-high-speed operation. (The touch probe is optional.)



Roller LMG

The roller-type LM Guideway has been adopted to ensure excellent rigidity and accuracy of the linear travel axes.



Linear scale (standard for all axes)

All axes are equipped with the linear scale as a standard feature to maintain the highest degree of accuracy over many hours of operation.



Gantry loader option

Information on detailed specifications required prior to ordering.



OMP 400 option

FM 200/5AX implementation



Recommendations for Machine Operation

Unlike ball-screw-type machines, a water chiller is used to cool down the linear motors and direct-drive motors. As such, the machine is sensitive to the control temperature of the chiller. Since the water chiller is controlled according to the ambient temperature, machine accuracy can be maintained and guaranteed in a constant temperature environment.

- Recommended operating conditions: Ambient temperature: $20 \pm 1.5^\circ\text{C}$, Temperature change: 0.4°C/hr or less, $\pm 1.5^\circ\text{C}/24\text{hr}$, Relative humidity: 20~80%

Basic Information

Basic Structure
Travel Axis

Detailed Information

Options
Capacity Diagram
Specifications

Customer Support Service

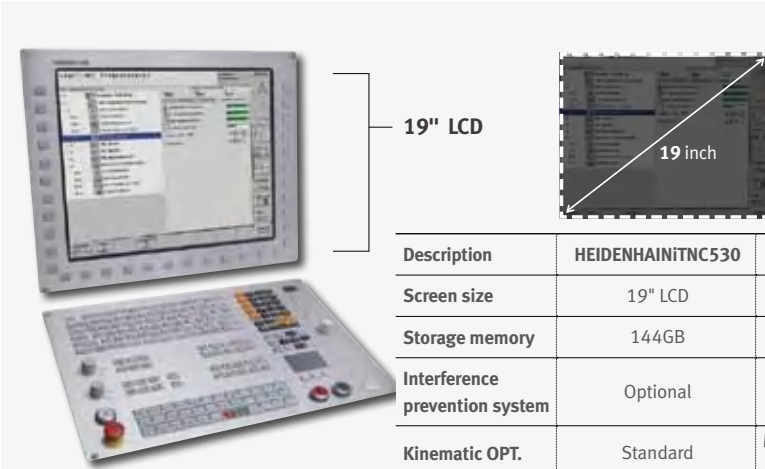

Description	HEIDENHAIN iTNC530	Remarks
Screen size	19" LCD	-
Storage memory	144GB	-
Interference prevention system	Optional	-
Kinematic OPT.	Standard	Measuring device not included
Look-ahead block	1024 blocks	-
3D line graphics	Standard	-

Convenient Features

Data are controlled in the folder structure; convenient communication enabled by USB devices.

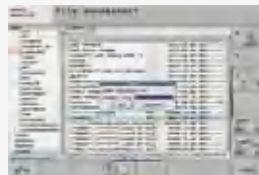
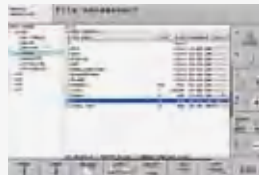

Various built-in pattern cycles for a wider scope of application.

Tool length, diameter and work pieces are measured using stored tool measurement graphic cycles.

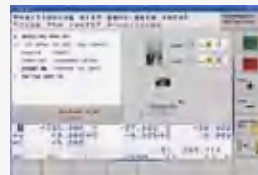

Graphic simulation

Before starting the actual cutting process, graphic process simulation of the NC program can be carried out using TEST RUN. The cutting time can be estimated.



Kinematic Opt (rotary axes center correction)

The interactively (graphically) supported fixed cycle enables easy measurement of the centers of the rotary axes.

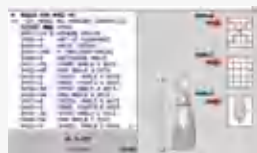

Collision Protection System option

The motion of the machine can be simulated on a 3D basis to substantially prevent mechanical interference. (Tool length is also recognized.)



External Dimensions

FM 200/5AX linear

Unit: mm (inch)

Top View

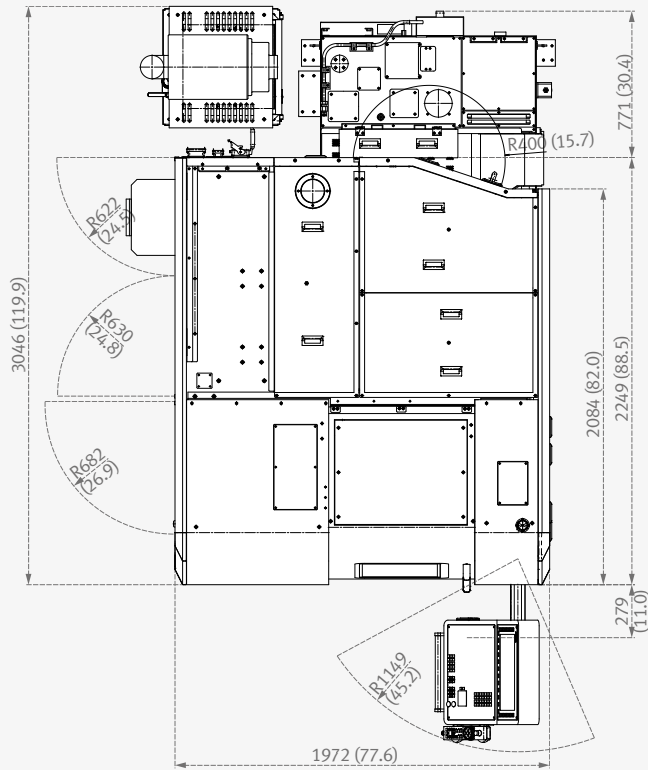

Front View

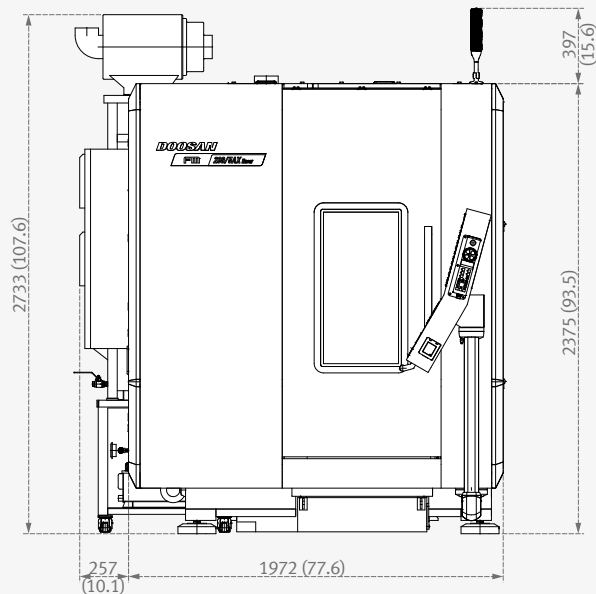

External Dimensions

Basic Information

Basic Structure
Travel Axis

FM 400 linear FM 350/5AX linear

Unit: mm (inch)

Detailed Information

Options
Capacity Diagram
Specifications

Customer Support Service

Top View

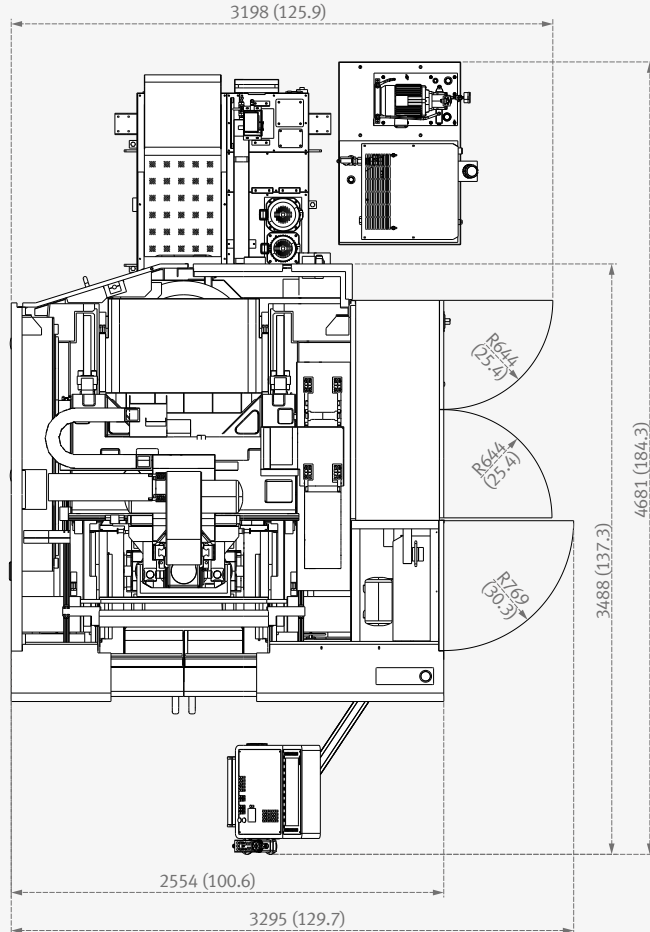

Front View

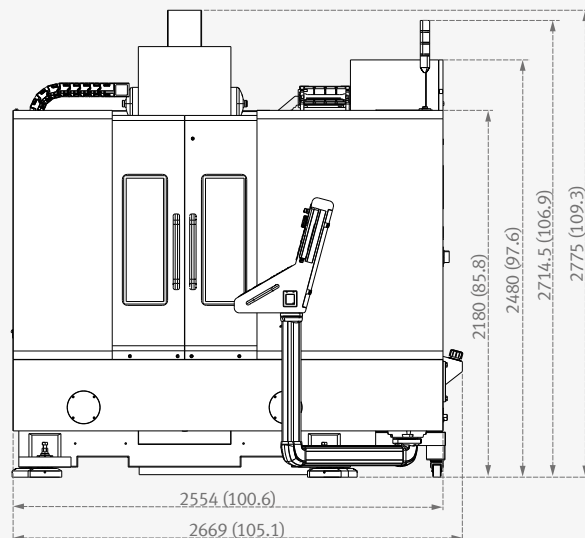
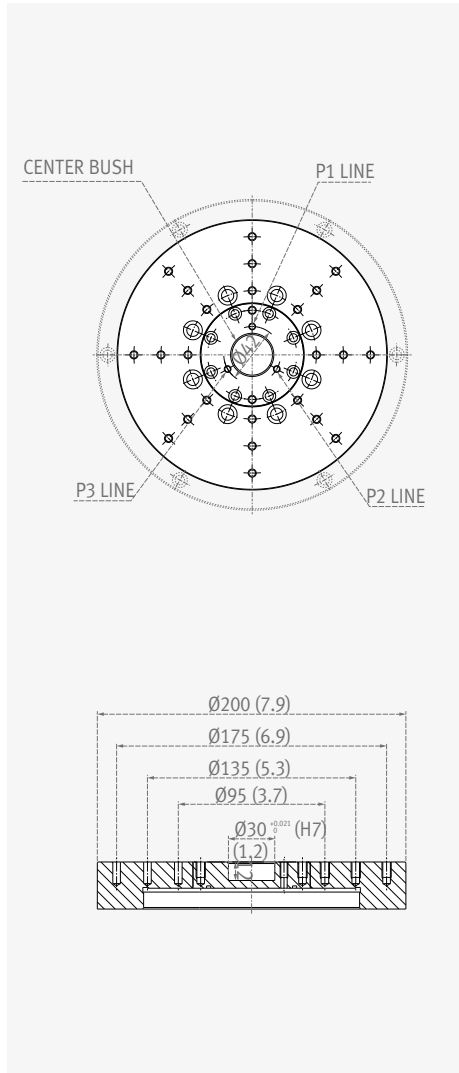

Table / Tool Shank

Table

Unit: mm (inch)

FM 200/5AX linear



FM 350/5AX linear

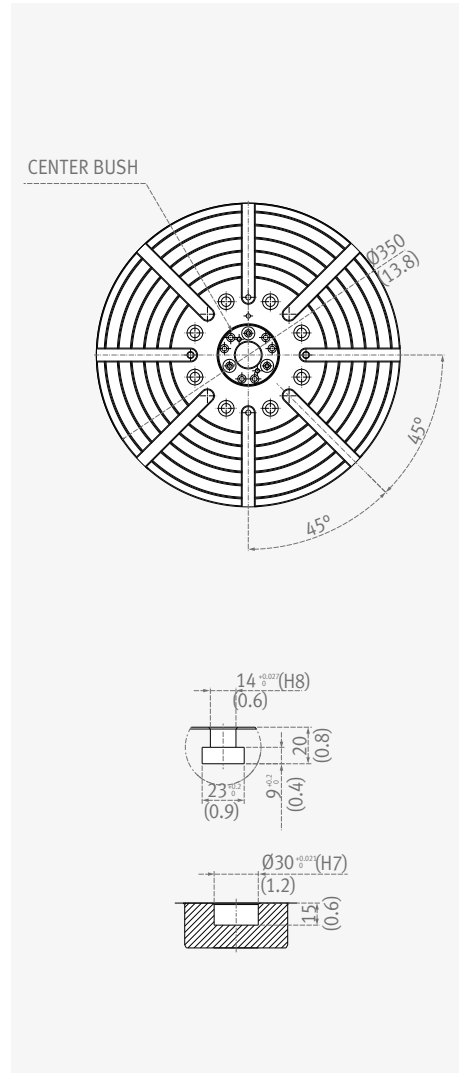

FM 400 linear

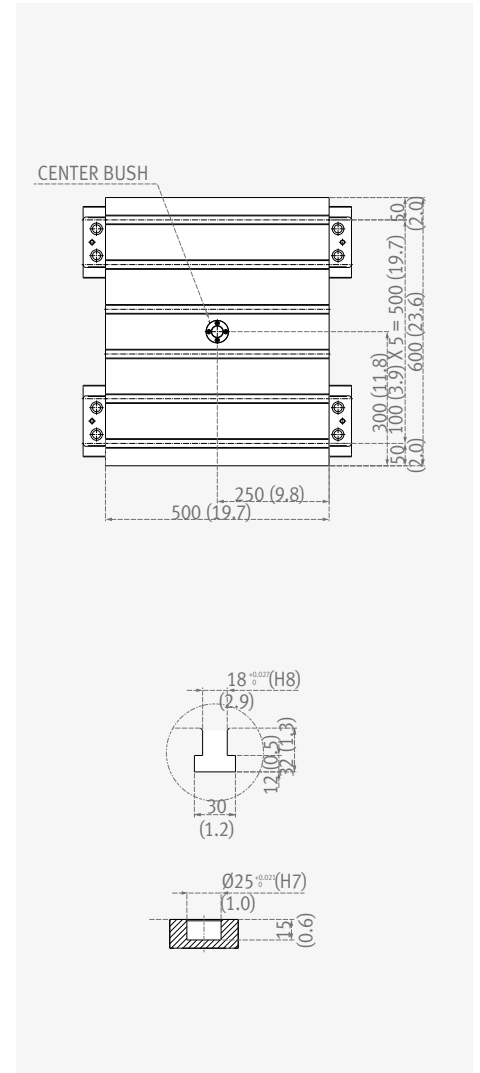

Tool Shank

Unit: mm (inch)

HSK E40

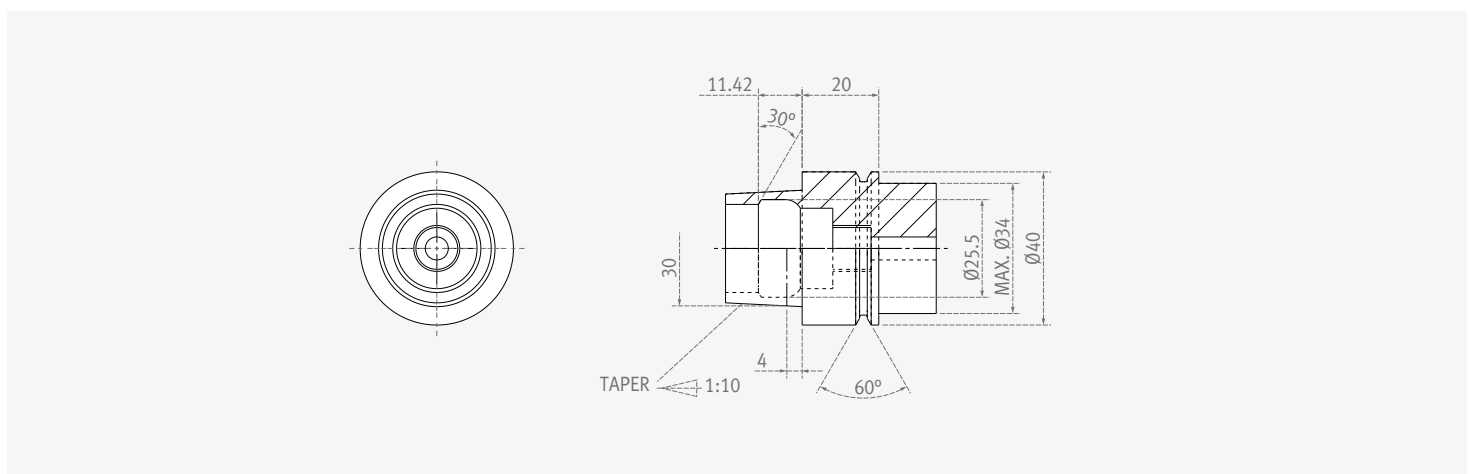

Machine Specifications

Basic Information

Basic Structure
Travel Axis

Detailed Information

Options
Capacity Diagram
Specifications

Customer Support Service



Description		Unit	FM 200/5AX linear	FM 350/5AX linear	FM 400 linear	
Travel	Travel distance	X-axis	mm (inch)	200 (7.9)	400 (15.7)	
		Y-axis	mm (inch)	340 (13.4)	600 (23.6)	
		Z-axis	mm (inch)	300 (11.8)	350 (13.8)	
		A-axis	deg	140 (-10 ~ +130)	240	-
		C-axis	deg	360		-
	Distance from spindle center to table top	mm (inch)	110~410 (4.3~16.1)	50~400 (2.0~15.7)	150~500 (5.9~19.7)	
Distance from spindle center to column	mm (inch)	230 (9.1)	300 (11.8)			
Feed rate	Rapid traverse rate	X-axis	m/min (ipm)	50 (1968.5)	80 (3149.6)	
		Y-axis	m/min (ipm)	50 (1968.5)	80 (3149.6)	
		Z-axis	m/min (ipm)	50 (1968.5)	80 (3149.6)	
		A-axis	r/min	100	50	-
		C-axis	r/min	200	100	-
	Cutting feed rate	m/min (ipm)	20 (787.4)	30 (1181.1)	30 (1181.1)	
Table	Table size	mm (inch)	∅ 200 (∅ 7.9)	∅ 350 (∅ 13.8)	500 x 600 (19.7 x 23.6)	
	Loading capacity	kg (lb)	15 (33.1)	100 (220.5)	600 (1322.8)	
Spindle	Max. spindle speed	r/min	40000			
	Spindle taper	-	HSK E40			
	Max. spindle torque	N-m (ft-lb)	3 (2.2)			
Automatic tool changer	Tool shank type	-	HSK E40			
	Tool storage capacity	ea	24	40		
	Max tool diameter	mm (inch)	50 (2.0)			
	Max. tool length	mm (inch)	180 (2.9)			
	Max. tool weight	kg (lb)	1 (2.2)			
	Tool selection	-	FIXED			
	Tool change time (tool to tool)	s	8	10		
Tool change time (chip to chip)	s	10	13			
Motor	Spindle motor power	kW (Hp)	12.6 (16.9)			
	Coolant pump motor power	kW (Hp)	0.7 (0.9)	1.5 (2.0)		
Power Source	Power consumption	kVA	66.4	88.3	63.5	
	Compressed air pressure	MPa (psi)	0.54 (78.3)			
Tank Capacity	Coolant tank capacity	L	310	300		
	Lubricant tank capacity	L	5			
Tank Capacity	Height	mm (inch)	2375 (93.5)	2775 (109.3)		
	Length	mm (inch)	2249 (88.5)	2585 (101.8)		
	Width	mm (inch)	1972 (77.6)	2669 (105.1)		
	Weight	kg (lb)	6800 (14991.2)	12000 (26455.1)		
Controller	-	HEIDENHAIN iTNC 530				

Recommended operating conditions:

Ambient temperature: 20 ± 1.5°C
Temperature change: < 0.4°C/h < ±1.5°C/24h
Relative humidity: 20~80%

**HEIDENHAIN
iTNC 530**

AXES CONTROL

- Controlled axes X, Y, Z, C, A 5 axes
- Simultaneously controllable axes
- Positioning / Linear interpolation 5 axes
- Circular interpolation 2 axes
- Helical interpolation 5 axes
- Feedrate override 0 - 150 %
- Least command increment 0.0001 mm (0.0001 inch)
- Least input increment 0.0001 mm (0.0001 inch)
- Maximum commandable value ±99999.999mm (±3937 inch)
- Pulse handle feed Portable manual pulse generator
- Machine Model : FM400 linear / FM 350 / 5AX linear
- Portable manual pulse generator
- Linear / non-linear axis error, backlash
- Reversal spikes during circular movement
- Offset, thermal expansion, stiction, sliding friction

SPINDLE FUNCTION

- Spindle orientation
- Spindle speed command S5 digits
- Spindle speed override 0 - 150 %

TOOL FUNCTION

- 3-dimensional tool compensation
- Number of tool offsets 999 ea
- Tool length compensation
- Tool management (tool table)
- Tool management (tool table) Tool numbers and names
- Tool management (tool table) Tool length L and tool radius R
- Tool management (tool table) Tool life management & replacement tool
- Tool number command
- Tool radius compensation

PROGRAMMING & EDITING FUNCTION

- Background editing
- Heidenhain conversational format programming
- Program memory Hard disk with 26GB for NC programs
No limit on number of programs
- 3-D touch probe application
- Touch probe functions for compensating workpiece misalignment
- Touch probe functions for setting data
- Touch probe functions for automatic workpiece measurement
- Block processing time 0.5 m [s]
- Contour elements
- Straight line, chamfer, circular arc, circle center, circle radius
- Corner rounding, tangentially connecting circle, B spline
- Coordinate transformation
- Coordinate shift, coordinate rotation

Mirror image, scaling

- Tilting the working plane
- Data interface RS - 232C / Ethernet (100Base T)
- Fixed cycle (canned cycle)
- Machine Model : FM400 linear
- Drilling cycle
- (drilling, pecking, reaming, boring, tapping, rigid tapping)
- Milling, finishing rectangular, circular pockets
- Linear and circular hole patterns
- Linear and circular hole patterns
- Milling pockets and islands
- Cylindrical surface interpolation
- FK free contour programming
- Mathematical functions
- +, -, x, ÷, √, sin, cos, tan, arcsin, arccos, arctan
- Logical comparison (=, ≠, <, >, ≤, ≥)
- Program jumps Subprograms, program section repeats
- Programming support
- Functions for approaching / departing the contour
- On- screen pocket calculator, structuring of programs
- Kinematic OPT
- Kinematic COMP
- Dynamic Collision Monitoring

GRAPHIC FUNCTIONS

- Gaphic display
- Interactive programming graphics
- Test run graphics (3-D representation)
- Program run graphics (3-D representation)
- MDI / CRT unit 19" TFT color flat panel

OPTIONAL SPECIFICATIONS

- Controlled axes Max. 12 axes in total
- Digitizing with 3-D triggering touch probe
- Digitizing with 3-D measuring touch probe

Product Overview

Basic Information

Basic Structure
Travel Axis

Detailed
Information

Options
Capacity Diagram
Specifications

Customer Support
Service

Responding to Customers Anytime, Anywhere



Global Service Support Network

Corporations

5

Dealer Networks

122

Technical Centers

18

Factories

3

Technical Center: Sales Support, Service Support, Parts Support

Doosan Machine Tools' Global Network, Responding to Customer's Needs nearby, Anytime, Anywhere

Doosan machine tools provides a system-based professional support service before and after the machine tool sale by responding quickly and efficiently to customers' demands. By supplying spare parts, product training, field service and technical support, we can provide top class support to our customers around the world.



Domestic Service Support Network

Integrated Support Centers	2	Sales Branch Offices	7	Post-Sales Service Centers	6	Designated Repair Service Centers	31
----------------------------	---	----------------------	---	----------------------------	---	-----------------------------------	----

Customer Support Service

We help customers to achieve success by providing a variety of professional services from pre-sales consultancy to post-sales support.

Supplying Parts



- Supplying a wide range of original Doosan spare parts
- Parts repair service

Field Services



- On site service
- Machine installation and testing
- Scheduled preventive maintenance
- Machine repair

Technical Support



- Supports machining methods and technology
- Responds to technical queries
- Provides technical consultancy

Training



- Programming / machine setup and operation
- Electrical and mechanical maintenance
- Applications engineering

FM linear series



Description	UNIT	FM 200/5AX linear	FM 350/5AX linear	FM 400 linear
Max. spindle speed	r/min	40000		
Motor power	kW (Hp)	12.6 (16.9)		
Tool taper	taper	HSK E 40		
Travel distance (X / Y / Z)	mm (inch)	200 / 340 / 300 (7.9 / 13.4 / 11.8)	400 / 600 / 350 (15.7 / 23.6 / 13.8)	
Tool storage capacity	ea	24	40	
Table size	mm (inch)	Ø 200 (Ø 7.9)	Ø 350 (Ø 13.8)	500 x 600 (19.7 x 23.6)
Table tilting / rotation angle (A / C)	deg	140 / 360	240 / 360	-
NC system	-	HEIDENHAIN		



Doosan Machine Tools

<http://www.doosanmachinetools.com>

www.facebook.com/doosanmachinetools

Optimal Solutions for the Future

Head Office

Yeonkang Bldg., 6th FL., 270, Yeonji-dong,
Jongno-gu, Seoul, Korea
Tel +82-2-3670-5345 / 5362
Fax +82-2-3670-5382

Doosan Machine Tools China

Room 101,201,301, Building 39 Xinzhuan Highway
No.258 Songjiang District,China Shanghai(201612)
Tel +86 21-5445-1155
Fax +86 21-6405-1472

Doosan Machine Tools Japan

#2412, Mita Kokusai Bldg. 1-4-28 Mita,
Minato-ku, Tokyo 108-0073, Japan
Tel +81 3 5730 9013
Fax +81 3 5730 9016

Doosan Machine Tools America

19A Chapin Rd., Pine Brook, NJ 07058, U.S.A.
Tel +1-973-618-2500
Fax +1-973-618-2501

Doosan Machine Tools Europe

Emdener Strasse 24, D-41540 Dormagen, Germany
Tel +49-2133-5067-100
Fax +49-2133-5067-111

Doosan Machine Tools India

106 / 10-11-12, Amruthahalli, Byatarayanapura,
Bellary road, Bangalore-560 092, India
Tel +91-80-4266-0122 / 121 / 100



* For more details, please contact Doosan Machine Tools.

* The specifications and information above-mentioned may be changed without prior notice.

* Doosan Machine Tools Co., Ltd. is a subsidiary of MBK Partners. The trademark  DOOSAN is used under a licensing agreement with Doosan Corporation, the registered trademark holder.