



Optimal Solutions for the Future

VM series



**Large, High-speed,
High-precision
Machining Center**

VM series

- VM 750 (L)
- VM 960 (L)
- VM 1260

ver. EN 160712 SU

Basic Information

Basic Structure
Cutting
Performance

Detailed Information

Options
Optimized Tool
Processing Solution
Capacity Diagram
Specifications

Customer Support Service



VM series

Vertical Machining Center Ideal for Mold Processing

Low-vibration built-in spindle and highest stroke in its class. Designed for both roughing and finishing, the VM Series provides a product line-up ranging from Unit 7 to Unit 12 sizes. The new design boasting improved operator convenience and work efficiency will raise users' productivity and create added value.



Contents

02 Product Overview

Basic Information

04 Basic Structure

08 Cutting Performance

Detailed Information

09 Standard / Optional Specifications

11 Optimized Tool Processing Solution

14 Capacity Diagram

20 Machine / NC Unit Specifications

22 Customer Support Service

Broad product line-up designed for diverse requirements

Complete line-up ranging from Unit #7 to #12 sizes.

- VM 750 (L) / VM 960 (L) / VM 1260

Highest reliability realized with a wide range of spindle speeds and excellent quality

- Dual contact spindle (standard)
- Gear type 6000 rpm / 8000 rpm
- Built-in type 12000 rpm

Control solution for processing high-quality molds

- High-speed, high-precision contour control
- Tool monitoring
- Optimal feed control



Basic Structure

High feedrate and precision have been realized with the adoption of a stable C-type column structure and bed design.

Rigid Construction for Heavy Duty Applications

- The rigidity is increased by effectively arranging the box type structure of bed, column and saddle.
- Rigidity and stability are assured with the wide box guide structure.
- The spindle head is supported by the wide guide way for the stable cutting performance.
- Wide z-side slide and wide y-side transport support prevent skewing and make it suitable for powerful, heavy cutting.



Exceptionally Durable All-in-One Single Frame Construction

The wide bed slide is heat-treated with high frequency providing outstanding performance during heavy duty cutting operations.



Radial Rib Structure

The processing is improved with the reduced weight and absorbed vibrations during heavy duty cutting.

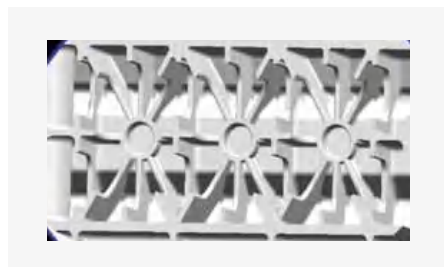

Coolant Recirculation System

The cleanliness and service life of the coolant have been improved.





Feed Shaft / Tool Magazine

Equipped with wide box-type guideways and a large-capacity tool changer.

Rapid Traverse

The adoption of a wide box guide structure delivers greater rigidity and stability. The entire upper surface of the saddle is equipped with slide bearings and oil grooves to prevent friction and wear.

Rapid traverse rate

VM 750 (L)	20 / 20 / 20 m/min	(787.4 / 787.4 / 787.4 ipm)
VM 960 (L)	16 / 16 / 16 m/min	(629.9 / 629.9 / 629.9 ipm)
VM 1260	12 / 12 / 12 m/min	(472.4 / 472.4 / 472.4 ipm)

Rapid traverse rate

Large diameter ball screw for powerful cutting

Fitted with high-precision, fixed ends, pre-tensioned double anchor structure ball screw. The nut is cooled on the outer rim to minimize thermal error, while direct-coupled structure delivers rapid responsiveness and excellent rigidity.



Minimized Idle Time

A high-speed cam-type tool changer has been adopted as a standard feature to deliver higher productivity. The loop-type magazine on the left side of the machine stores 40 tools as standard, and can be extended.

Minimized Idle Time

Tool change time (T-T-T)

2.5sec.

Tool magazine

VM 750 (L) / VM 960 (L)

30sec.

standard

40sec.

option

VM 1260

40sec.

standard



Table

Basic type and long type table specifications are available in addition to diverse machining solutions.

Table

The extended X axis travel distance allows the setting up and cutting of wider workpieces of various shapes.

Largest work area in its class

X-axis x Y-axis

VM 750 (L)

1600 x 800 (1900 x 800)mm
(63.0 x 31.5 (74.8 x 31.5) inch)

VM 960 (L)

2400 x 950 (2600 x 950)mm
(94.5 x 37.4 (102.4 x 37.4) inch)

VM 1260

2800 x 1260mm
(110.2 x 49.6 inch)



Greatest table loading capacity in its class

VM 750 (L)

3000 (3500)kg
(6613.8 (7716.1) lb)

VM 960 (L)

4000 (4500)kg
(8818.4 (9920.7) lb)

VM 1260

8000kg
(17636.7 lb)

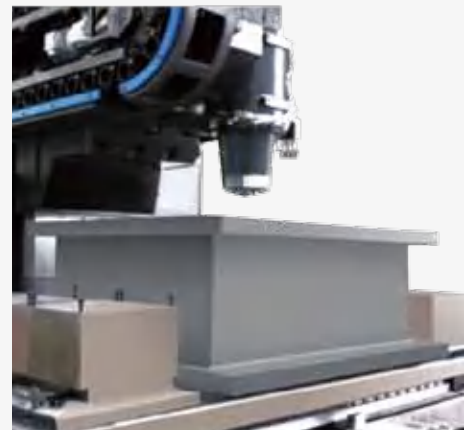

Spindle

The stable thermal-displacement-preventive structure minimizes spindle taper error at high speed. The wide range of speeds and excellent quality of the spindle guarantee the highest reliability.

Gear Type

- **Powerful cutting of large workpieces:** Powerful processing capability of large workpieces with maximum torque is offered by 2-stage gear drive.
- **High-speed tapping:** Standard adoption of rigid tap allows high speed tapping without the tap holder.
- **High rigidity and stability:** Rigid angular contact bearing is adopted to assure rigidity and stability by maintaining the rigidity even during heavy duty cutting.

Max. spindle speed

6000 r/min 8000 r/min option

Motor (30 min/cont.)

VM750 (L), VM 960 (L)

18.5 / 15kW

(24.8 / 20.1 Hp)

VM 1260

22 / 18.5kW

(29.5 / 24.8 Hp)

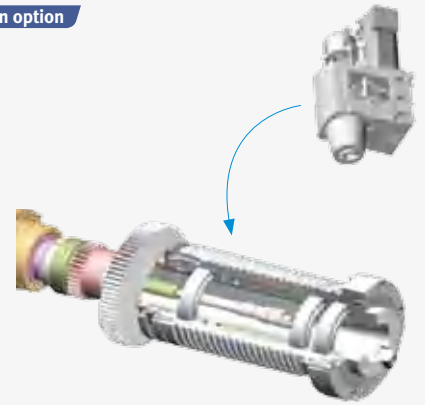

Dual contact spindle

Dual contact spindle (BIG PLUS) adopted as a standard feature

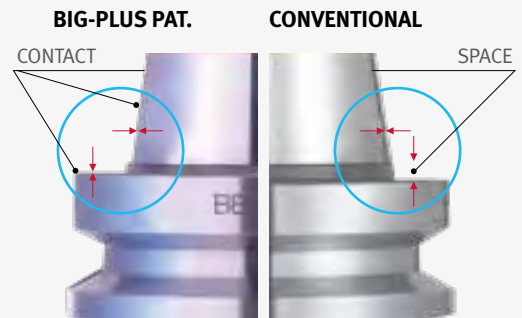

Built-in Type option

Max. spindle speed

12000 r/min

Motor (30 min/cont.)

30 / 25 kW

(40.2 / 33.5 Hp)

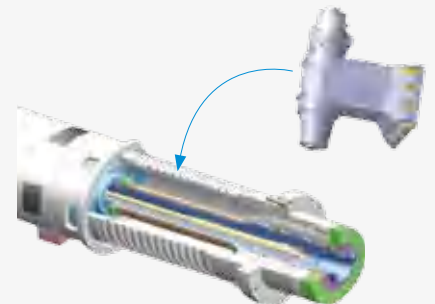

Rigid and precise spindle

Adoption of 100 diameter rigid ceramic bearing and oil supply (oil mist) method assure high precision even during the extended time of high speed rotation.

Highest speed spindle in its class

Adoption of low vibration built-in motor offers optimum molding with the highest spindle speed (12000 r/min) and the highest torque of 419.44 N·m (309.5 ft-lb) in its class.



Provides high-productivity and high-accuracy in a variety of machining operations.

Basic Information

Basic Structure
Cutting
Performance

Detailed Information

Options
Optimized Tool
Processing Solution
Capacity Diagram
Specifications

Customer Support Service

Face mill Carbon steel (SM45C)			
ø125mm (4.9 inch) Face mill (8Z)			
Machining rate cm ³ /min (inch ³ /min)	Spindle speed r/min	Feedrate mm/min (ipm)	
660 (40.3)	500	1660 (65.4)	
End mill Carbon steel (SM45C)			
ø63mm (2.5 inch) Endmill (4Z)			
Machining rate cm ³ /min (inch ³ /min)	Spindle speed r/min	Feedrate mm/min (ipm)	
635 (38.8)	500	320 (12.6)	
Face mill Gray casting (GC25)			
ø125mm (4.9 inch) Face mill (8Z)			
Machining rate cm ³ /min (inch ³ /min)	Spindle speed r/min	Feedrate mm/min (ipm)	
1260 (76.9)	500	2520 (99.2)	
End mill Gray casting (GC25)			
ø63mm (2.5 inch) Endmill (4Z)			
Machining rate cm ³ /min (inch ³ /min)	Spindle speed r/min	Feedrate mm/min (ipm)	
1012 (61.8)	500	320 (12.6)	
Drill Carbon steel (SM45C)			
ø73mm (2.9 inch) Drill (2Z)			
Spindle speed r/min	Feedrate mm/min (ipm)		
500	140 (5.5)		
Tap Carbon steel (SM45C)			
ø73mm (2.9 inch) Drill (2Z)			
Tool	Spindle speed r/min		
M42 x P4,5	400		

* The results, indicated in this catalogue are provides as example. They may not be obtained due to differences in cutting conditions and environmental conditions during measurement.

Machining Accuracy

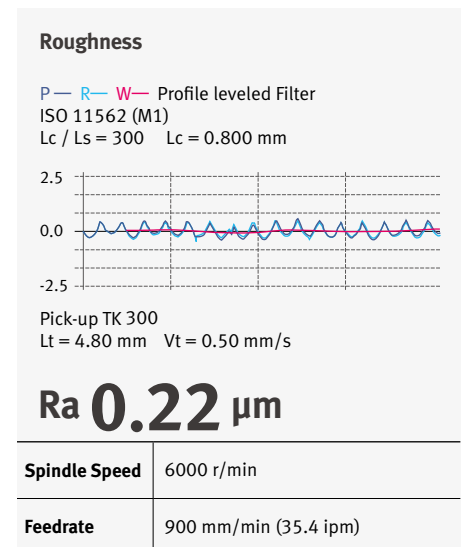
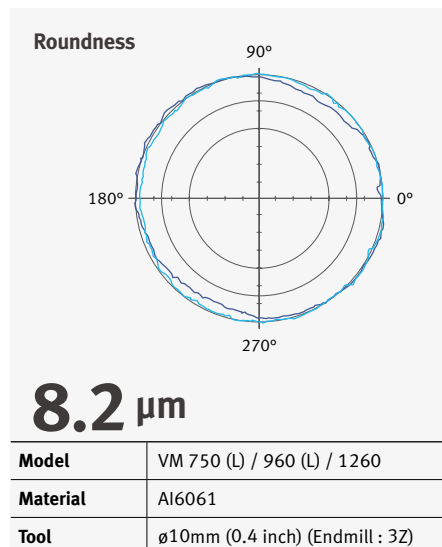

* The results, indicated in this catalogue are provides as example. They may not be obtained due to differences in cutting conditions and environmental conditions during measurement.



Standard / Optional Specifications

Various options are available to satisfy various requirements.

● Standard ○ Optional X N/A

NO.	Description	Features	VM750 (L)	VM 960 (L)	VM 1260	VM1260
1	Spindle	6000 r/min	18.5/15 kW (24.8/20.1 Hp), 587.4 (433.5) N-m(ft-lb)	●	●	X
2			22/18.5 kW (29.5/24.8 Hp), 698.8 (515.7) N-m(ft-lb)	○	○	●
3			26/22 kW (34.9/29.5 Hp), 825.9 (609.5) N-m(ft-lb)	○	○	○
4		8000 r/min	18.5/15 kW (24.8/20.1 Hp), 587.4 (433.5) N-m(ft-lb)	○	○	X
5			22/18.5 kW (29.5/24.8 Hp), 698.8 (515.7) N-m(ft-lb)	○	○	○
6			26/22 kW(34.9/29.5 Hp), 825.9 (609.5) N-m(ft-lb)	○	○	○
7		12000 r/min	30/25 kW (40.2/33.5 Hp), 238.1 (175.7) N-m(ft-lb)	○	○	○
8	Magazine	Tool storage capacity	30 ea	●	●	X
9		40 ea	○	○	●	
10	Tool shank type	BIG PLUS BT50		●	●	●
11		BIG PLUS CAT50		○	○	○
12		BIG PLUS DIN50		○	○	○
13	Coolant	FLOOD	0.15 MPa (0.4 kW (0.5 Hp))	●	●	●
14			0.1 MPa (1.1 kW (1.5 Hp))	○	○	○
15		TSC	None	●	●	●
16			2 MPa (1.5 kW (2.0 Hp))	○	○	○
17			2 MPa (4 kW (5.4 Hp))	○	○	○
18			7 MPa (5.5 kW (7.4 Hp))	○	○	○
19		Shower coolant		○	○	○
20	Chip disposal	Chip conveyor	Chip pan	●	●	●
21			Hinged rear type	○	○	○
22		Chip bucket	Forklift type	○	○	○
23			Rotation type	○	○	○
24		Air blower		○	○	○
25		Air gun		○	○	○
26	Coolant gun		○	○	○	
27	Precision machining option	Linear scale	X / Y / Z axis	○	○	○
28		DSQ 1 (200 block)		●	●	●
29		DSQ 2 (DSQ 1, DATA SERVER 1G)		○	○	○
30		DSQ 3 (DSQ 2, 600 block)		○	○	○
31		DSQ 4 (DSQ 3, 1000 block)		○	○	○
32	Measurement & Automation	Automatic tool measurement	TS27R_RENISHAW	○	○	○
33			OTS_RENISHAW	○	○	○
34		Automatic tool breakage detection		○	○	○
35		Automatic workpiece measurement	OMP60_RENISHAW	○	○	○
36	Others	LED Work light		●	●	●
37		3 Color signal tower		●	●	●
38		EZ Guide i		○	○	○
39		Automatic power off		○	○	○

* Please contact Doosan for more information.



Basic Information

- Basic Structure
- Cutting
- Performance

Detailed Information

- Options
- Optimized Tool
- Processing Solution
- Capacity Diagram
- Specifications

Customer Support Service

Interface for Additional Axis

- Recommended rotary table size
: VM 750 (L) : ø320 mm /
VM 960 (L) : ø500 mm
VM 1260 : ø500 mm
- Please check the driving system (hydraulic or pneumatic) of the rotary table before ordering the machine.

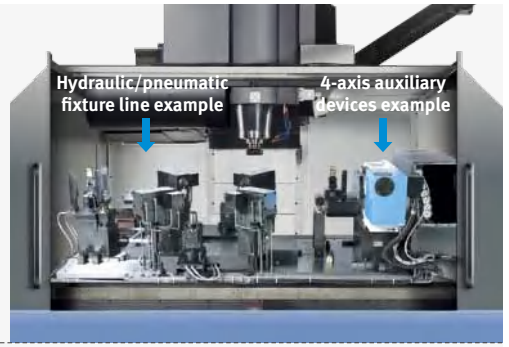

Fixture check list (for hydraulic / pneumatic fixtures)

- Pressure source
Hydraulic P/T A/B
Pneumatic P/T A/B
- Number of ports
 1pair (2-PT 3/8"port) 2pair (4-PT 3/8"port)
 3pair (6-PT 3/8"port)
- Hydraulic power unit
Supply scope : End user DOOSAN
 Doosan standard unit 24L / min, 4.9 MPa
 Other requirements _____ L / min, _____MPa

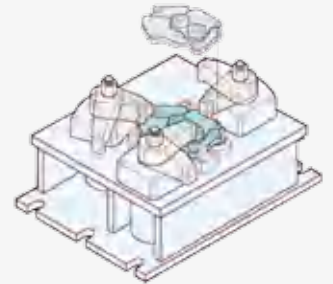

* Please contact Doosan for more information.

Easy Chip Disposal



Built-in spiral-type coil conveyor at front and rear of the machine



Lift chip conveyor for fast chip disposal (VM 1260)

Diverse Options

Numerous options are offered for greater efficiency and customer convenience.



Coolant Gun option

Coolant gun helps keeping the work environment clean.



Through-spindle coolant spray system



Oil skimmer

Optimized Tool Processing Solution

Superior surface finishes and machining accuracy are achieved through using standard processing solutions such as high-speed / high-precision contour control and thermal displacement compensation.

DSQ High Speed / High Precision Contour Control

* DSQ : Doosan Super Quality

- **DSQ1**
(AICC2 _ 200 Block + Machining condition selection function)
- **DSQ2 option**
(DSQ1 + Data server [1GB])
- **DSQ3 option**
(DSQ2 + High speed processing _ 600 Block)



DAFC The Optimal Feed Control option

* DAFC : Doosan Adaptive Feedrate Control

Optimal feed control is ensured by real-time spindle load detection.

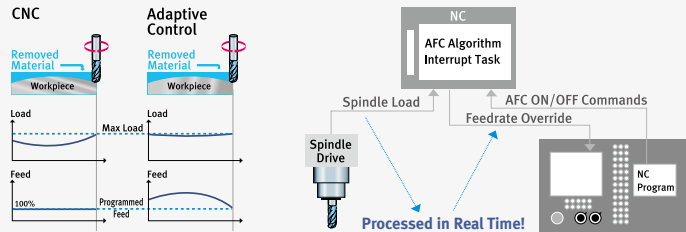

DTMM Tool Load Monitoring System (DTMM*) option

* DTMM : Doosan Tool load Monitoring for Machining Centers

The technology of protecting tool and machine in abnormal load during the cutting process

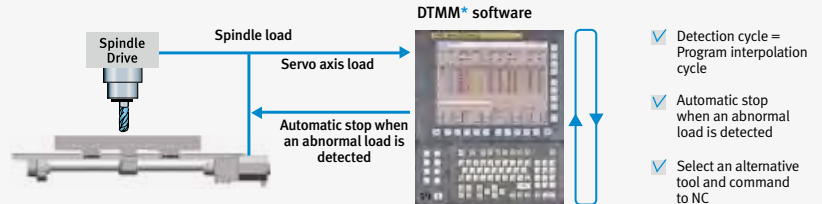

DSTC Smart thermal displacement multi compensation technology

* DSTC : Doosan Smart Thermal Control

Realizes high-quality, high-precision machining with smoothing thermal displacement compensation of the spindle and structure.

Compensation of static displacement of spindle

Compensates changes in tool position caused by expansion of the spindle shaft at high speed.

Structure thermal displacement compensation

Compensates irregular deflection or expansion of the structure due to ambient temperature using a multiple temperature sensors.



Compensation of structure thermal displacement

Thermal error of the spindle caused by heat accumulation is compensated with 5 algorithms including a smoothing function.



Without smoothing

With smoothing

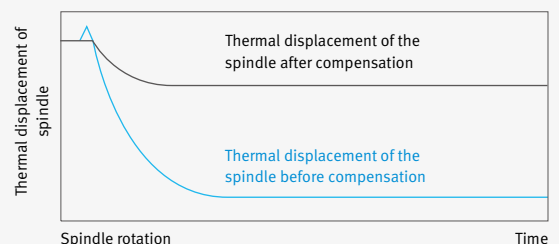

Basic Information

Basic Structure
Cutting
Performance

Detailed Information

Options
Optimized Tool
Processing Solution
Capacity Diagram
Specifications

Customer Support Service

These Doosan software packages have been customized to provide fast and easy setup of tooling, workpiece, and program. These functions minimize the idle time caused by process setup and maximize the machine's productivity.

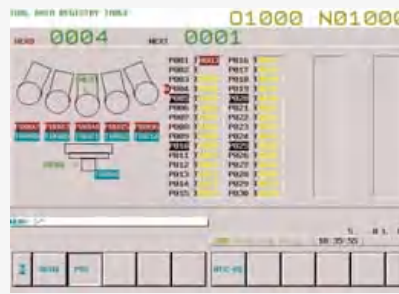

Tool Data Registry Table

Displays the information on the tools in the pot in 2D graphics.

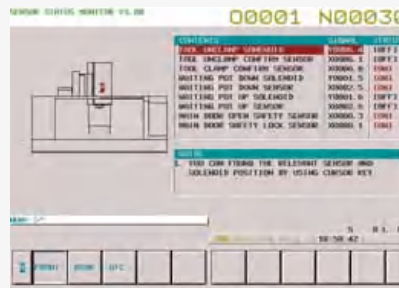

Engraving option

Allows character engraving on the workpiece.

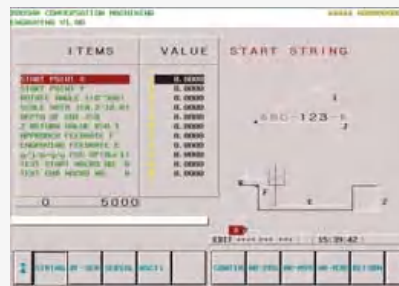

ATC Recovery Help

When ATC is stopped (malfunction or emergency), this function guides the operator to recover the machine back to its normal state.

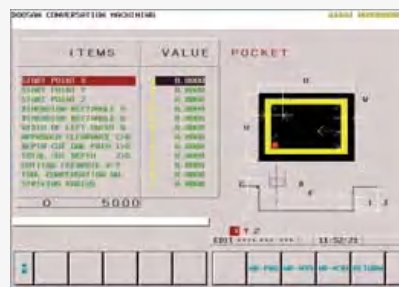

Renishaw Gui (Tool measure)
(Work measure option)

Enables automatic measurement of tool length, tool diameter, and work coordinates, and detects tool damage using an interactive method.



Sensor Status Monitor

Shows solenoid valve and sensor status without the electric diagram.



Pattern Cycle

Pattern cycle programs can be created using an interactive way of parameter input.



Tool Load Monitor option

Detects tool damage and wear by setting limits on the load for spindle and axis to minimize mechanical damages.

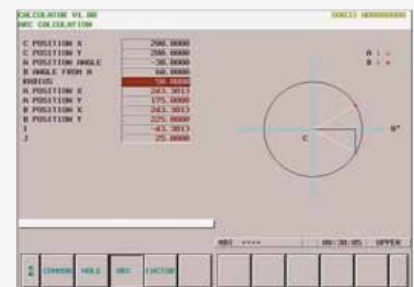

Calculator

Provides all functions of a general calculator plus automatic calculation of cutting size and conditions.

Spindle Power – Torque Diagram

Gear Type

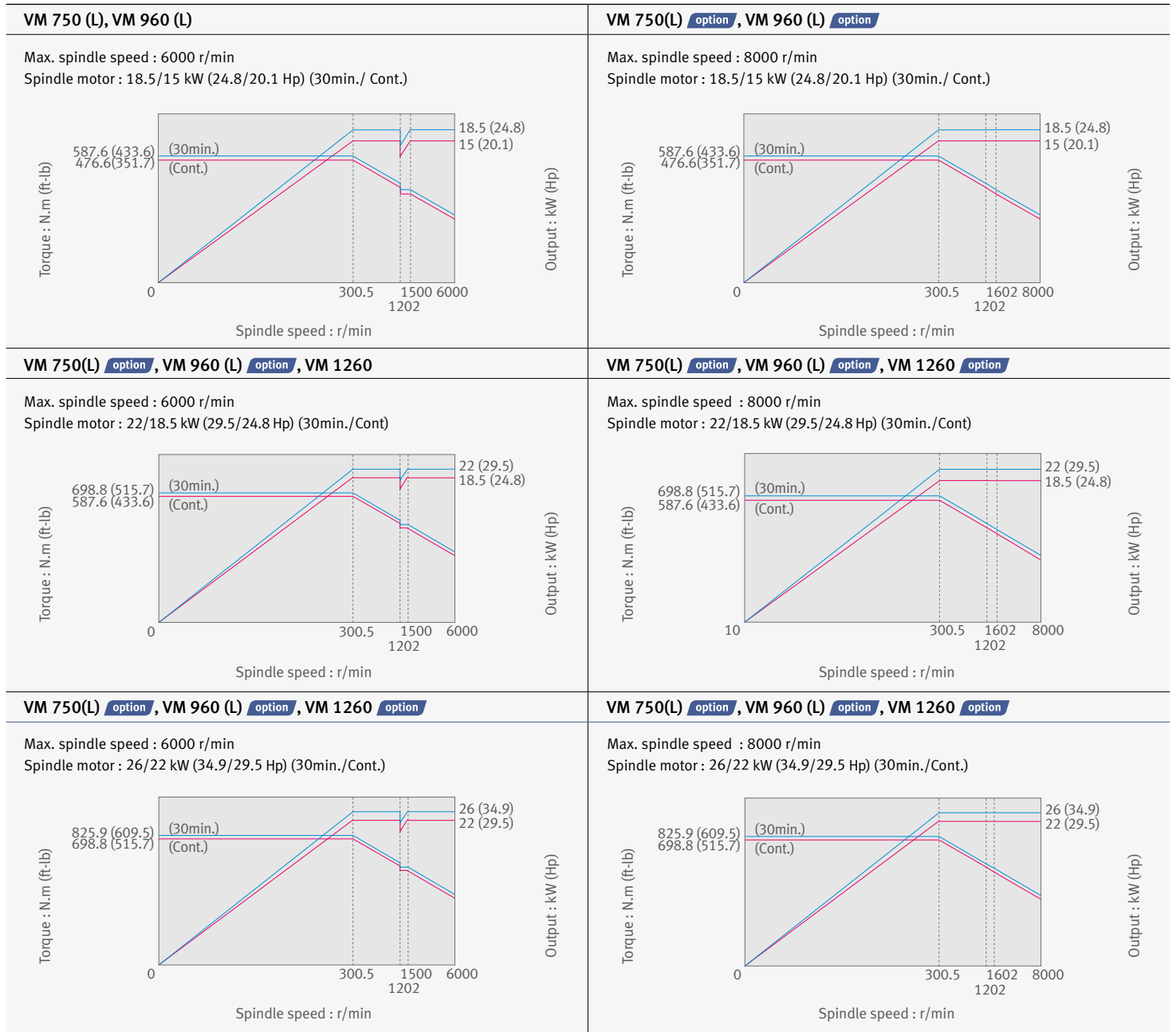

Built-in Type

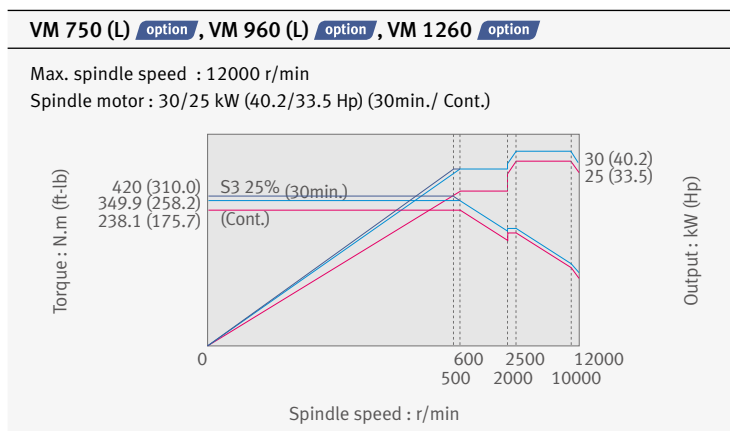

External Dimensions

Basic Information

VM 750 / 750L (Half Cover, for domestic market)

Unit: mm (inch)

Basic Structure
Cutting
Performance

Detailed Information

Options
Optimized Tool
Processing Solution
Capacity Diagram
Specifications

Customer Support Service

Top View

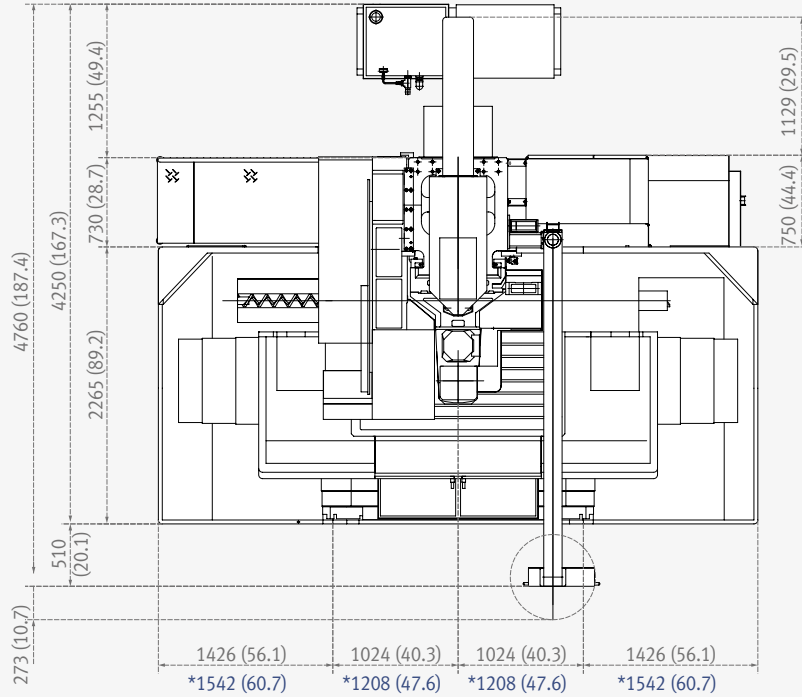

Front View

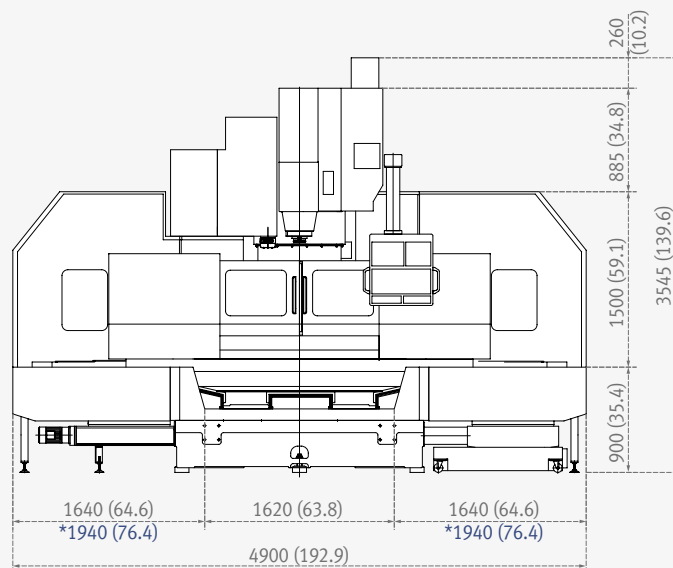

External Dimensions

Basic Information

VM 960 / 960L (Half Cover, for domestic market)

Unit: mm (inch)

- Basic Structure
- Cutting
- Performance

Detailed Information

- Options
- Optimized Tool
- Processing Solution
- Capacity Diagram
- Specifications

Customer Support Service

Top View

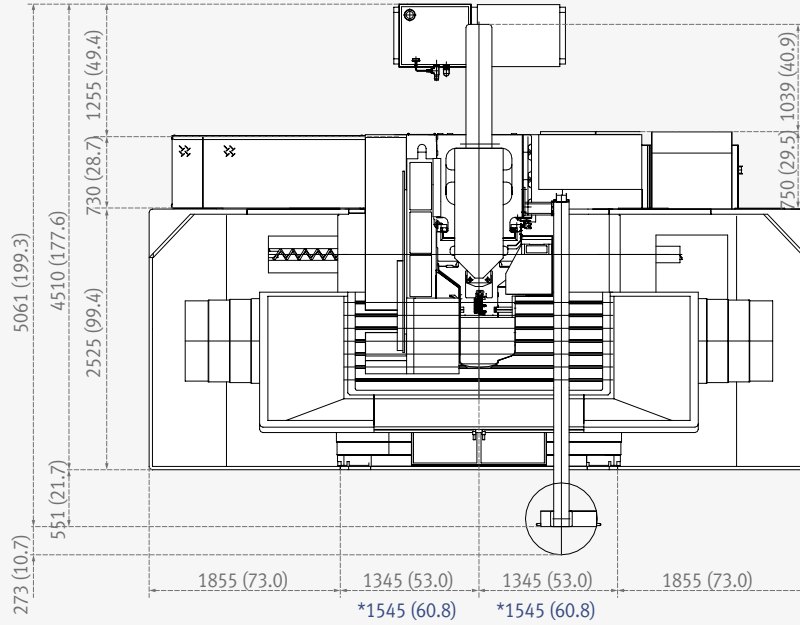

Front View

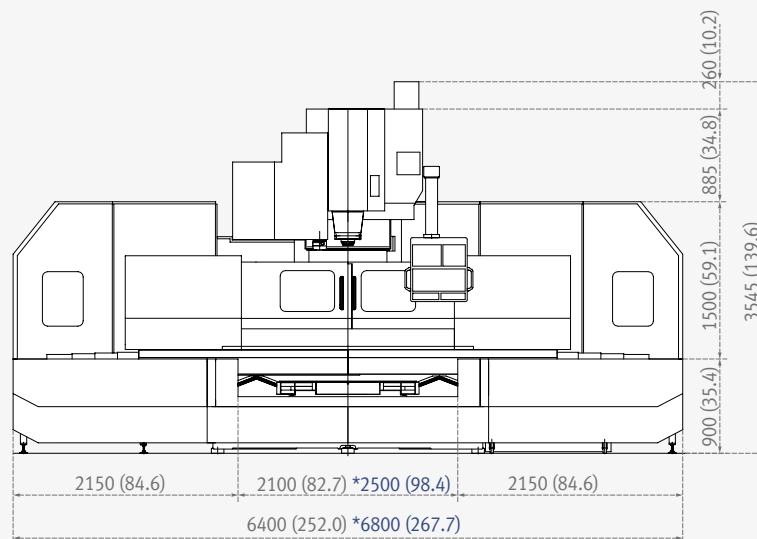

External Dimensions

VM 960 / 960L (Full Cover) **option**

Unit: mm (inch)

Top View

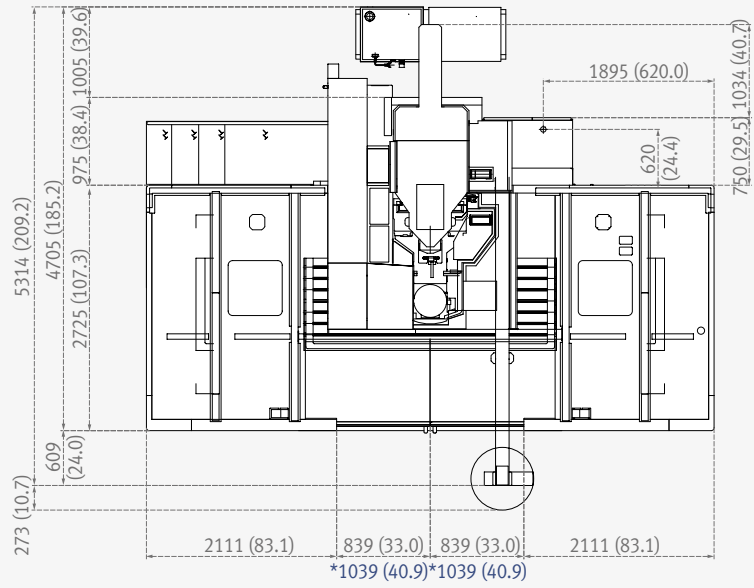

Front View

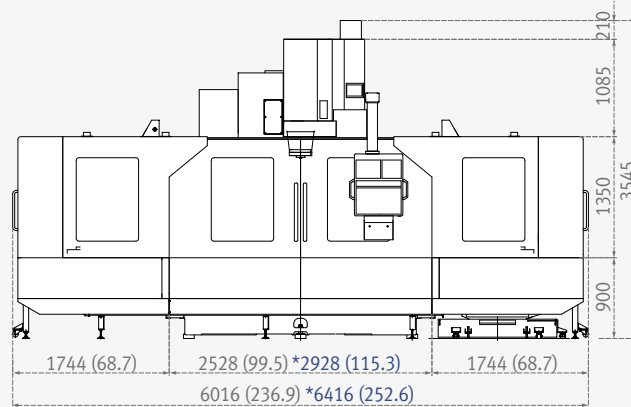

* : VM 960L

External Dimensions

Basic Information

VM 1260 (Full Cover)

Unit: mm (inch)

- Basic Structure
- Cutting
- Performance

Detailed Information

- Options
- Optimized Tool
- Processing Solution
- Capacity Diagram
- Specifications

Customer Support Service

Top View

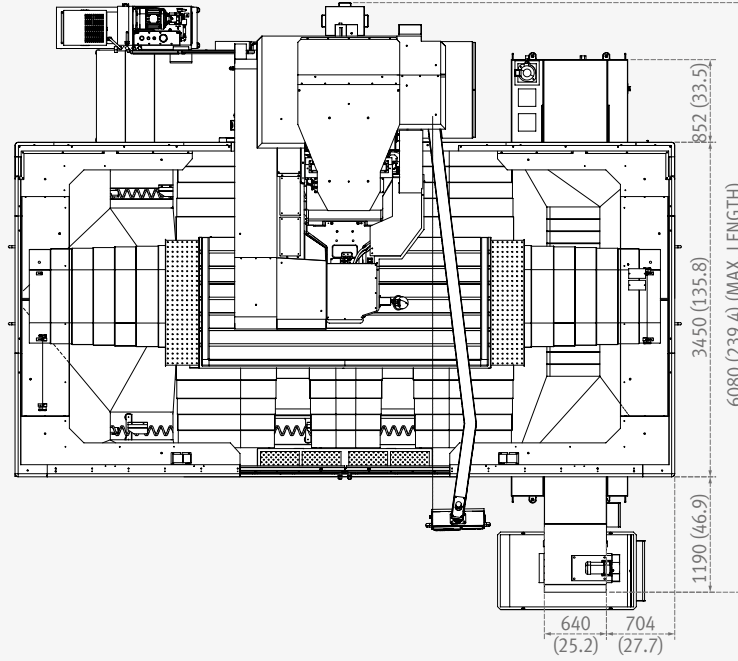

Front View

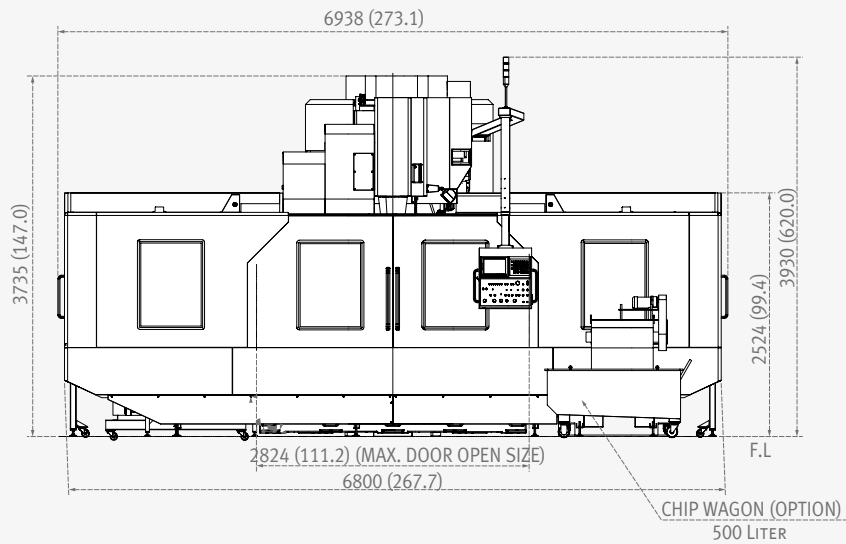

Tool Shank / Table

Tool Shank

Unit: mm (inch)

BT 50

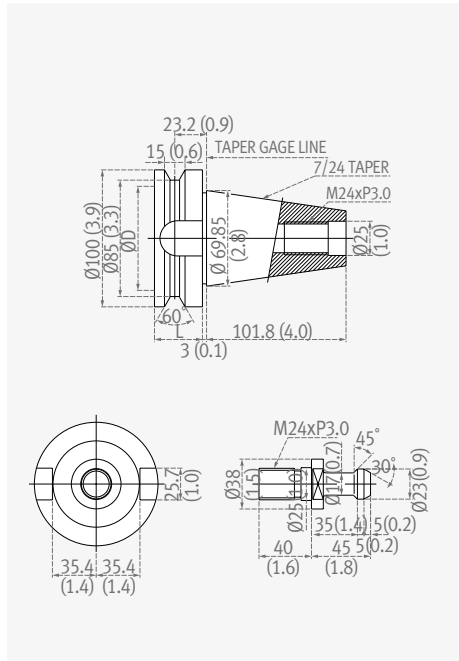

CAT 50

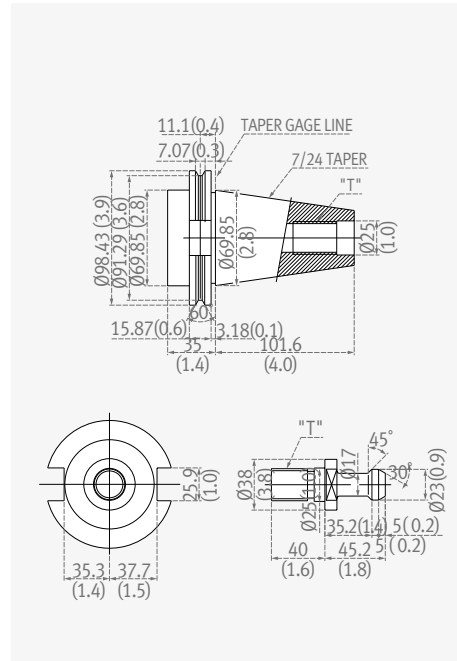

DIN 50

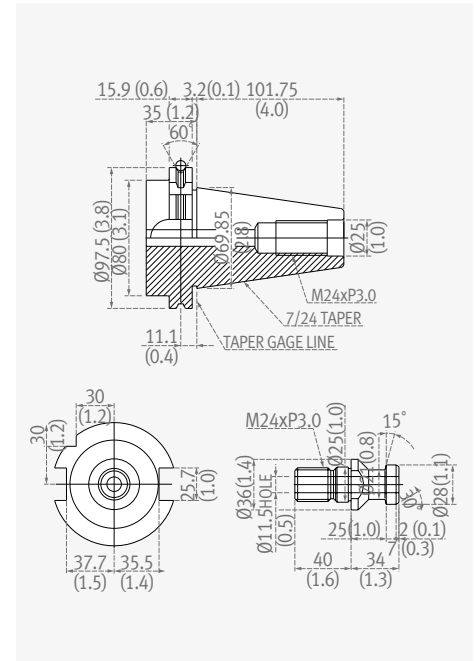
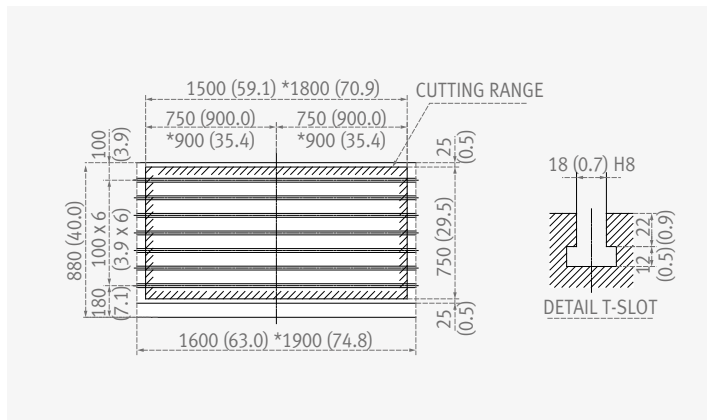

Table (for both half & full cover types)

Unit: mm (inch)

VM 750 / 750L



VM 960 / 960L

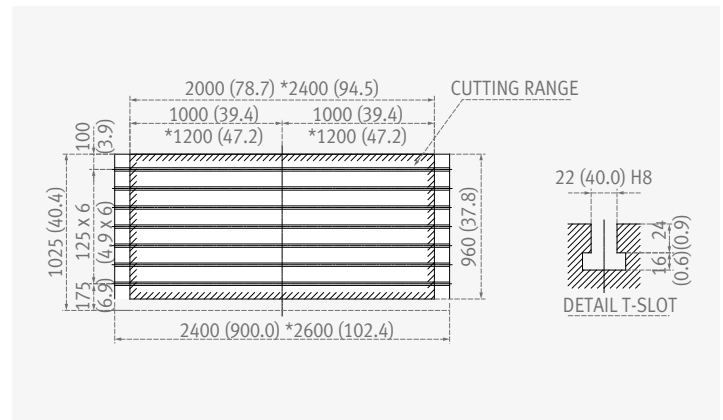

VM 1260

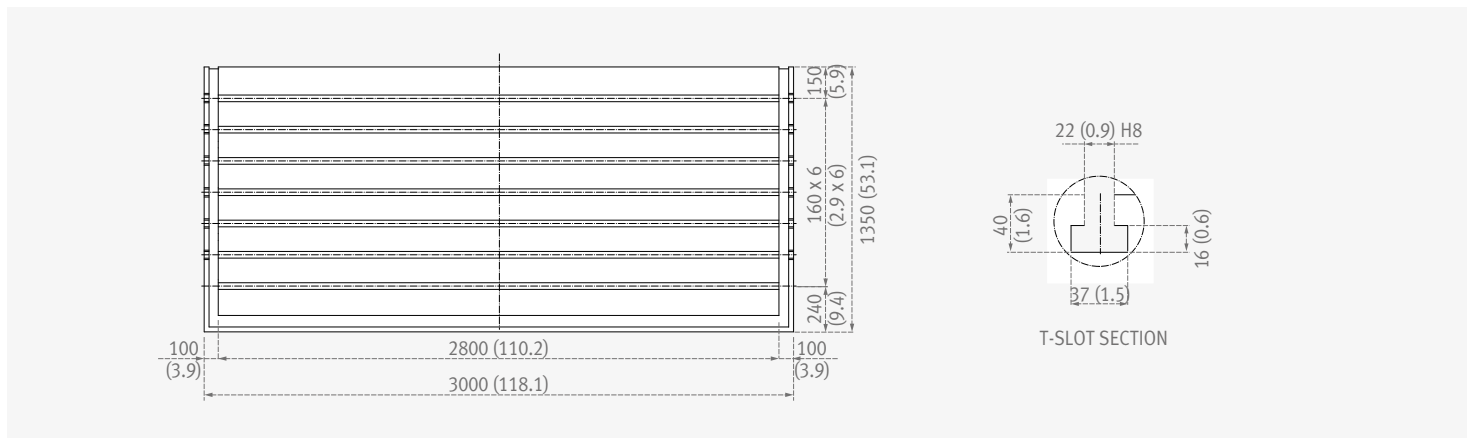

Machine Specifications

Basic Information

Basic Structure
Cutting
Performance



Detailed Information

Options
Optimized Tool
Processing Solution
Capacity Diagram
Specifications

Customer Support Service

Description		Unit	VM750	VM 750L	VM 960	VM 960L	VM 1260
Travel	X-axis	mm (inch)	1500 (59.1)	1800 (70.9)	2000 (78.7)	2400 (94.5)	2500 (98.4)
	Y-axis	mm (inch)	750 (29.5)		960 (37.8)		1260 (49.6)
	Z-axis	mm (inch)	800 (31.5)				900 (35.4)
	Distance from spindle nose to table top	mm (inch)	200 - 1000 (7.9 - 39.4)				200 - 1100 (7.9 - 43.3)
	Distance from spindle nose to column	mm (inch)	865 (34.1)		1005 (39.6)		1320 (52.0)
Feedrate	Rapid feedrate (X, Y, Z)	m/min (ipm)	20 / 20 / 20 (787.4 / 787.4 / 787.4)		16 / 16 / 16 (629.9 / 629.9 / 629.9)		12 / 12 / 12 (472.4 / 472.4 / 472.4)
	Cutting feedrate	mm/min (ipm)	10000		8000		6000
Table	Table size	mm (inch)	1600 x 800 (63.0 x 31.5)	1900 x 800 (74.8 x 31.5)	2400 x 950 (94.5 x 37.4)	2600 x 950 (102.4 x 37.4)	2800 x 1260 (110.2 x 49.6)
	Loading capacity	kg (lb)	3000	3500	4000	4500	8000
Spindle	Max. spindle speed	r/min	6000 (8000, 12000)*				
	Taper		ISO#50 7/24 Taper				
	Max. torque	N-m (ft-lb)	587.6 {698.8, 793.8}* , {420}*				698.8 {793.8}* , {420}*
ATC	Type of tool shank		BIG PLUS MAS403 BT50				
	Tool storage capacity	ea	30 {40}*				40
	Max. tool diameter	mm (inch)	ø125 (ø4.9)				
	Max. tool dia. (when a nearest port is empty)	mm (inch)	ø230 (ø9.1)				
	Max. tool length	mm (inch)	350 (13.8)				
	Max. tool weight	kg (lb)	15 (33.1)				
	Tool selection type		Memory Random				
	Tool change time (tool to tool)	s	2.5				
Motor	Spindle motor power (30 min)	kW (Hp)	18.5 / 15 {22 / 18.5, 30 / 25}* (24.8 / 20.1 {29.5 / 24.8, 40.2 / 33.5}*)				22 / 18.5 {18.5 / 15, 30 / 25}* (29.5 / 24.8 {24.8 / 20.1, 40.2 / 33.5}*)
	Travel motor (X / Y / Z)	kW (Hp)	7 / 7 / 7 (9.4 / 9.4 / 9.4)				9 / 9 / 7 (12.1 / 12.1 / 9.4)
Power Consumption	Electric power	kVA	60 {70}*				65 {73}*
	Compressed air pressure	Mpa (psi)	0.54 (78.3)				
Tank Capacity	Coolant tank capacity	L	480		520		800
	Lubricant tank capacity	L	12				
Control	Height (H)	mm (inch)	3545 (139.6)				3930 (154.7)
	Dimension (L x W)	mm (inch)	4927 x 4900 {5126 x 4766}* (194.0 x 192.9 {201.8 x 187.6}*)	4927 x 5500 {5126 x 5126}* (194.0 x 216.5 {201.8 x 201.8}*)	5138 x 6400 {5392 x 6016}* (202.3 x 252.0 {212.3 x 236.9}*)	5138 x 6800 {5392 x 6416}* (202.3 x 267.7 {212.3 x 252.6}*)	5645 x 6938 (222.2 x 273.1)
	Weight	kg (lb)	14000 (30864.3)	14800 (32627.9)	20000 (44091.8)	21000 (46296.4)	31000 (68342.3)

* { } : Option

NC Unit Specifications

● Standard ○ Optional X N/A

FANUC 31i

Item	Spec.	FANUC 31i	
Axes Control	Additional controlled axes	5 axes in total	○
	Least command increment	0.001 mm / 0.0001"	●
	Least input increment	0.001 mm / 0.0001"	●
	Interpolation type pitch error compensation		○
Interpolation & Feed Function	2nd reference point return	G30	●
	3rd / 4th reference return		○
	Inverse time feed		○
	Cylindrical interpolation	G07.1	○
	Helical interpolation B	Only Fanuc 30i	-
	Smooth interpolation		○
	NURBS interpolation		○
	Involute interpolation		○
	Helical involute interpolation		○
	Bell-type acceleration/deceleration before look ahead interpolation		○
	Smooth backlash compensation		●
	Automatic corner override	G62	○
	Manual handle feed rate	x1, x10, x100 (per pulse)	●
	Handle interruption		●
	Manual handle retract		○
	Manual handle feed 2/3 unit		●
	Nano smoothing	AI contour control II is required.	○
	AICC II	200 BLOCK	●
	AICC II	400 BLOCK	○
	High-speed processing	600 BLOCK	X
Look-ahead blocks expansion	1000 BLOCK	○	
DSQ I	AICC II (200block) + Machining condition selection function	●	
DSQ II	AICC II (200block) + Machining condition selection function + Data server (1GB)	○	
DSQ III	AICC II with high speed processing (600block) + Machining condition selection function + Data server (1GB)	○	
Spindle & M-code Function	M- code function		●
	Retraction for rigid tapping		●
	Rigid tapping	G84, G74	●
Tool Function	Number of tool offsets	64 ea	●
	Number of tool offsets	99 / 200 / 400 / 499 / 999 / 2000 ea	○
	Tool nose radius compensation	G40, G41, G42	●
	Tool length compensation	G43, G44, G49	●
	Tool life management		●
	Addition of tool pairs for tool life management		○
	Tool offset	G45 - G48	○
Programming & Editing Function	Custom macro		●
	Macro executor		●
	Part program storage	256KB(640m)	●
	Part program storage	512KB(1,280m) / 1MB(2,560m) / 2MB(5,120m) / 4MB(1,0240m), 8MB(2,0480m)	○
	Inch/metric conversion	G20 / G21	●
	Number of Registered programs	500 ea	●
	Number of Registered programs	1000 / 4000 ea	○
	Optional block skip	9 BLOCK	○
	Playback function		○
	Addition of workpiece coordinate system	G54.1 P1 - 48 (48 pairs)	48 pairs
Addition of workpiece coordinate system	G54.1 P1 - 300 (300 pairs)	○	
OTHERS FUNCTIONS (Operation, setting & Display, etc)	Embedded Ethernet		●
	USB memory interface	Only Data Read & Write	●
	High speed skip function		○
	Polar coordinate command	G15 / G16	○
	Polar coordinate interpolation	G12.1 / G13.1	○
	Programmable mirror image	G50.1 / G51.1	○
	Scaling	G50, G51	○
	Single direction positioning	G60	○
	Pattern data input		○
	Jerk control	AI contour control II is required.	○
	Fast Data server with 1GB PCMCIA card		○
	Fast Ethernet		○
	3-dimensional coordinate conversion		○
	3-dimensional tool compensation		○
	Figure copying	G72.1, G72.2	○
	Machining time stamp function		○
	EZ Guide I with 10.4" Color TFT	Doosan infracore Conversational Programming Solution -When the EZ Guide i is used, the Dynamic graphic display cannot application	○
	Dynamic graphic display (with 10.4" Color TFT LCD)	Machining profile drawing. -When the EZ Guide i is used, the Dynamic graphic display cannot application	○
	3-dimensional tool compensation		OPT
	Figure copying	G72.1, G72.2	OPT
Machining time stamp function		OPT	
EZ Guide I with 10.4" Color TFT	Doosan infracore Conversational Programming Solution -When the EZ Guide i is used, the Dynamic graphic display cannot application	OPT	
Dynamic graphic display (with 10.4" Color TFT LCD)	Machining profile drawing. -When the EZ Guide i is used, the Dynamic graphic display cannot application	OPT	

Responding to Customers Anytime, Anywhere

Basic Information

- Basic Structure
- Cutting
- Performance

Detailed Information

- Options
- Optimized Tool
- Processing Solution
- Capacity Diagram
- Specifications

Customer Support Service

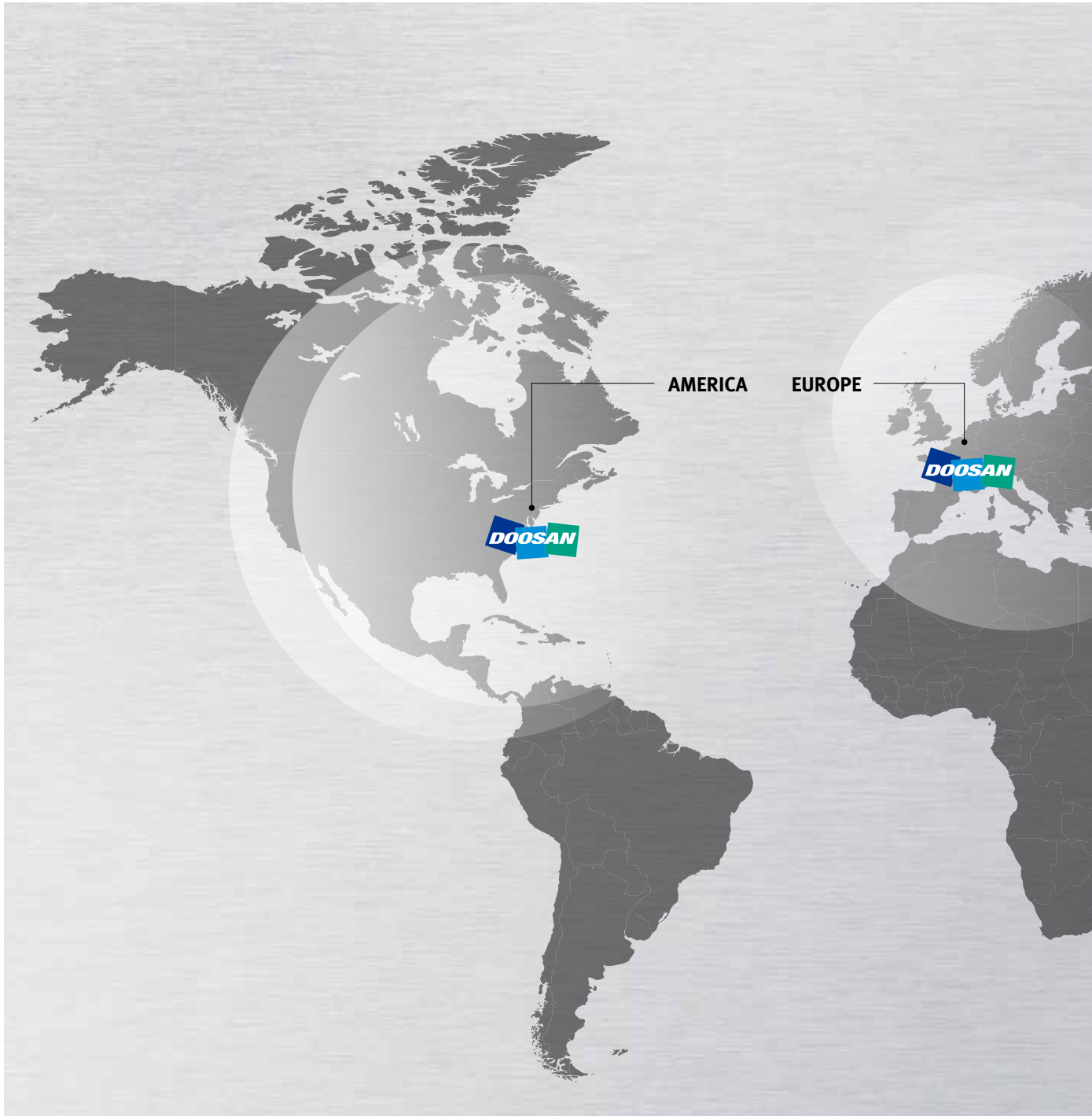

Global Service Support Network

Corporations

5

Dealer Networks

122

Technical Centers

18

Factories

3

Technical Center: Sales Support, Service Support, Parts Support

Doosan Machine Tools' Global Network, Responding to Customer's Needs nearby, Anytime, Anywhere

Doosan machine tools provides a system-based professional support service before and after the machine tool sale by responding quickly and efficiently to customers' demands. By supplying spare parts, product training, field service and technical support, we can provide top class support to our customers around the world.



Domestic Service Support Network

Integrated Support Centers	2	Sales Branch Offices	7	Post-Sales Service Centers	6	Designated Repair Service Centers	31
----------------------------	---	----------------------	---	----------------------------	---	-----------------------------------	----

Customer Support Service

We help customers to achieve success by providing a variety of professional services from pre-sales consultancy to post-sales support.

Supplying Parts



- Supplying a wide range of original Doosan spare parts
- Parts repair service

Field Services



- On site service
- Machine installation and testing
- Scheduled preventive maintenance
- Machine repair

Technical Support



- Supports machining methods and technology
- Responds to technical queries
- Provides technical consultancy

Training



- Programming / machine setup and operation
- Electrical and mechanical maintenance
- Applications engineering

VM series



Description		UNIT	VM 750	VM 750L	VM 960	VM 960L	VM 1260
Axes Travel Distance	X-axis	mm (inch)	1500 (59.1)	1800 (70.9)	2000 (78.7)	2400 (94.5)	2500 (98.4)
	Y-axis	mm (inch)	750 (29.5)		960 (37.8)		1260 (49.6)
	Z-axis	mm (inch)	800 (31.5)				900 (35.4)
Table Size (X x Y)		mm (inch)	1600 x 800 (900.0 x 31.5)	1900 x 800 (74.8 x 31.5)	2400 x 950 (94.5 x 40.0)	2600 x 950 (102.4 x 40.0)	2800 x 1260 (110.2 x 49.6)
Table Loading Capacity		kg (lb)	3000 (6613.8)	3500 (7716.1)	4000 (8818.4)	4500 (9920.7)	8000 (17636.7)
Max. Spindle Speed		r/min	6000 {8000, 12000}*				
No. of Tool Storage		ea	30		30 {40}*		40

*{ } Option



Doosan Machine Tools

<http://www.doosanmachinetools.com>

www.facebook.com/doosanmachinetools

Optimal Solutions for the Future

Head Office

Yeonkang Bldg., 6th FL., 270, Yeonji-dong,
Jongno-gu, Seoul, Korea
Tel +82-2-3670-5345 / 5362
Fax +82-2-3670-5382

Doosan Machine Tools China

Room 101,201,301, Building 39 Xinzhuan Highway
No.258 Songjiang District,China Shanghai(201612)
Tel +86 21-5445-1155
Fax +86 21-6405-1472

Doosan Machine Tools Japan

#2412, Mita Kokusai Bldg. 1-4-28 Mita,
Minato-ku, Tokyo 108-0073, Japan
Tel +81 3 5730 9013
Fax +81 3 5730 9016

Doosan Machine Tools America

19A Chapin Rd., Pine Brook, NJ 07058, U.S.A.
Tel +1-973-618-2500
Fax +1-973-618-2501

Doosan Machine Tools Europe

Emdener Strasse 24, D-41540 Dormagen, Germany
Tel +49-2133-5067-100
Fax +49-2133-5067-111

Doosan Machine Tools India

106 / 10-11-12, Amruthahalli, Byatarayanapura,
Bellary road, Bangalore-560 092, India
Tel +91-80-4266-0122 / 121 / 100



* For more details, please contact Doosan Machine Tools.

* The specifications and information above-mentioned may be changed without prior notice.

* Doosan Machine Tools Co., Ltd. is a subsidiary of MBK Partners. The trademark  **DOOSAN** is used under a licensing agreement with Doosan Corporation, the registered trademark holder.