



Optimal Solutions for the Future

DBC series



**Horizontal
Boring Machine**

DBC series

DBC 110S
DBC 130S / SL

DBC 110 II
DBC 130 / L
DBC 250 / L II

ver. EN 160919 SU

Basic Information

Diverse Line-up
High-Rigidity &
High-Precision
User Convenience

**Detailed
Information**

Options
Capacity Diagram
Specifications

**Customer Support
Service**



DBC II series DBC S series

Column Moving Type NC Boring Machine Featuring the State-of-the-Art Technologies

The DBC series, ranging from compact to super-size models, satisfies customers' requirements with DOOSAN's advanced technical prowess. A product line-up has been established for processing from middle to largest size parts including die / mold parts. We are improving productivity and creating values for our customers on the basis of our design improvements including enhanced operating convenience and efficiency.



Contents

02 Product Overview

Basic Information

04 Diverse Line-up

08 High-Rigidity & High-Precision Structure

11 User Convenience

Detailed Information

16 Standard / Optional Specifications

18 Diagrams

24 Machine / NC Unit Specifications

30 Customer Support Service

Diversified Line-up for Faster Response to Customers' Requirements

The DBC Series offers a wide line-up from compact to large models, from heavy-duty type to high-speed mold processing type.

- DBC II series
- DBC S series

Enhanced Performance through High-Rigidity & High-Precision Structure

A high-rigidity and high-precision structure has been adopted to improve heavy-duty machining performance.

- A high-rigidity and high-precision structure has been adopted to improve heavy-duty machining performance.
- B-axis rotary table equipped with high-precision encoder as a standard
- B-axis rotary table equipped with high-precision encoder as a standard

Increased Convenience and Productivity

The DBC Series offers various options and customized control functions for maximum user convenience.

- Automatic Tool Changer (ATC)
- Automatic Pallet Changer (APC)
- Various head attachments
- Doosan Easy Operation package

Product Overview

Basic Information

Diverse Line-up
High-Rigidity &
High-Precision
User Convenience

Detailed Information

Options
Capacity Diagram
Specifications

Customer Support Service

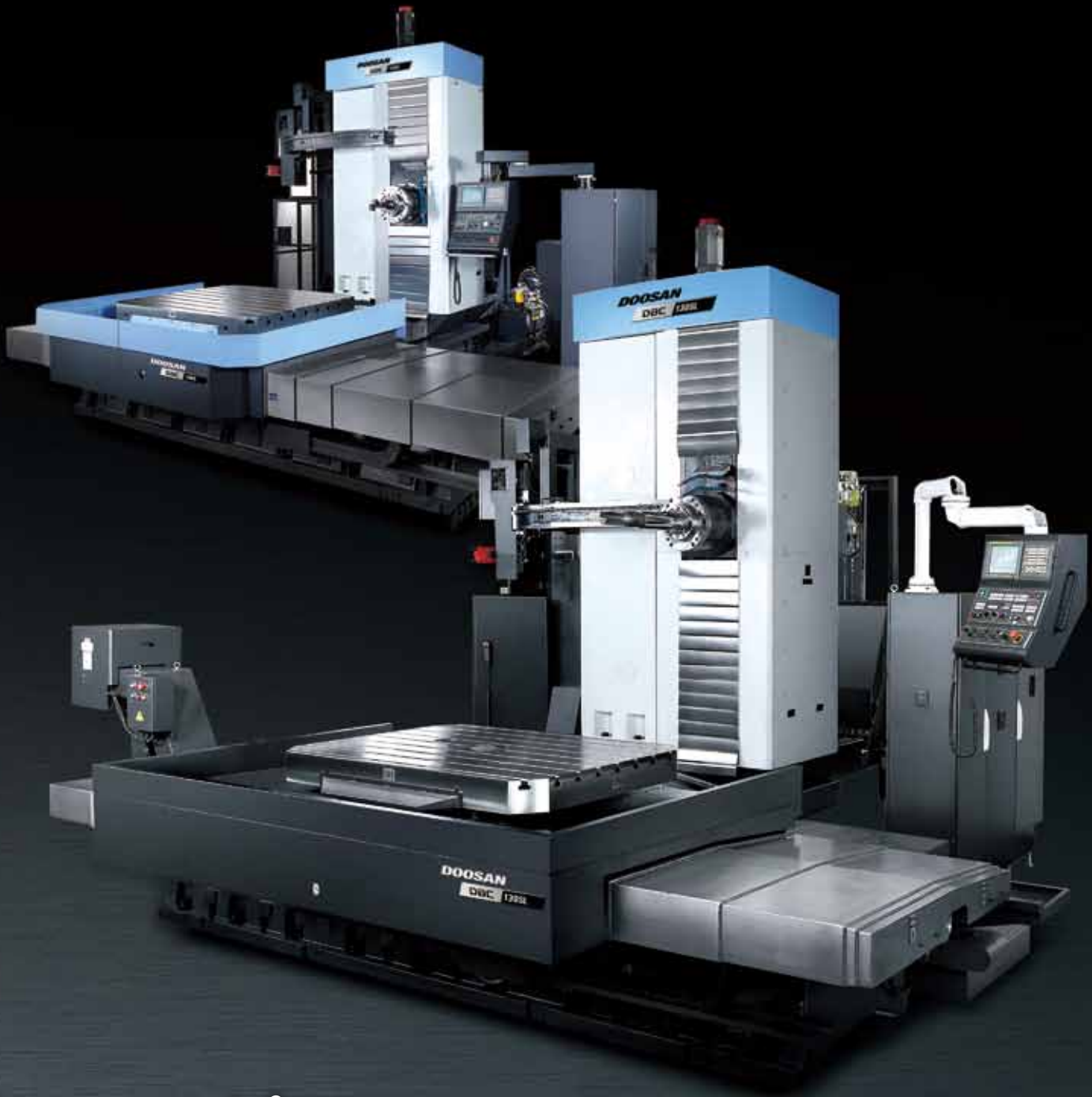

Diverse Line-up

Complete line-up ranging from compact to super-large types, and from heavy-duty to high-speed machining models is prepared for better and faster response to customer requests.

Optimal Solutions



Diverse Line-up

The DBC series provides various models covering compact, high-productivity, multi-functional, heavy duty and large workpieces.



Spindle

Nose-type head structure allows easy access to the workpiece and minimal protrusion of boring spindle enables stable cutting.



Diverse Line-up

The DBC series provides a wide line-up of models covering compact, high-productivity, multi-functional, heavy loads and large workpieces.

DBC S series

Compact type DBC 110S / 130S / 130SL

- Designed in compact size for small-medium size works
- Compact structure minimizes machine footprint

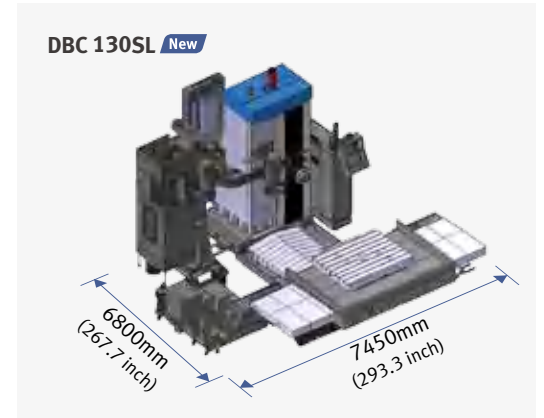
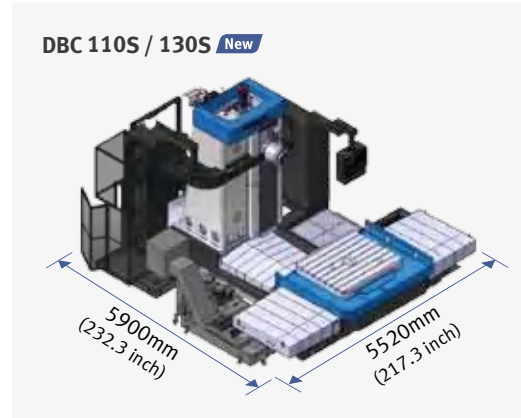

DBC II series

Small / medium-sized, high-productivity DBC 110 II

- High-productivity model featuring high-speed spindle
- Superior for deep cutting – boring operation is possible up to the table center due to W-axis feeding

Multi-purpose (Standard) DBC 130 II / 250 II

- A best-selling, standard model with a sales record of more than 1,000 units for the last decade – continuously upgraded with long-term design know-how and production technology.
- Shortest delivery time by modular system design.

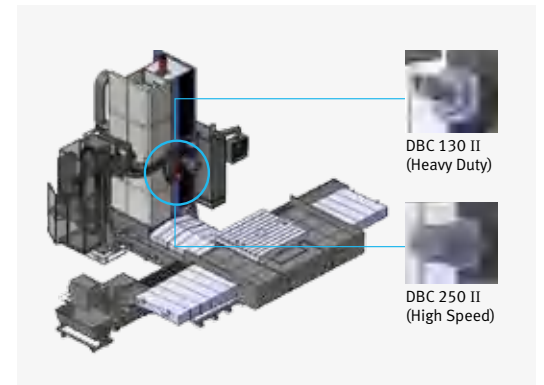
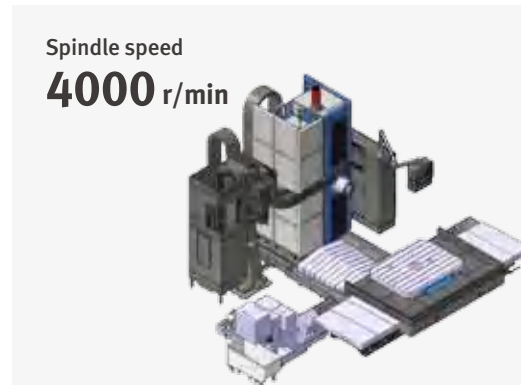

Large workpieces DBC 130L II / DBC 250L II

- Suitable for machining large workpieces

X / Y / Z axes travel distance
4000 / 2500 / 2000 mm
(157.5 / 98.4 / 78.7 inch)

Max. workpiece diameter (without splash guard)

- DBC 130 II / 250 II
Ø3900 mm (153.5 inch)
- DBC 130L II / 250L II
Ø4800 mm (189.0 inch)



Spindle

Basic Information

Diverse Line-up
High-Rigidity &
High-Precision
User Convenience

Detailed Information

Options
Capacity Diagram
Specifications

Customer Support Service

Nose-type head structure allows easy access to the work piece and minimal protrusion of boring spindle enables stable cutting operation.

Stable cutting performance of highly-rigid spindle

Supported by highly-rigid bearings, the spindle is designed to bear very high axial working load. In addition, the spindles of the DBC Series have further reinforced rigidity providing improved cutting performance when the W-axis is in protruding position.

DBC S series

DBC 110S / DBC 130S / DBC 130SL

Offer high-speed, high-power spindles to different boring sizes for higher productivity

Model	Spindle Speed r/min	Spindle motor kW(Hp)	Torque N·m(ft·lbs)	
DBC 110S	3000	26 / 22 (34.9 / 29.5) (30min/cont.)	1137 {1273}* (839.1 {939.5})*	
		{30 / 22 (40.2 / 29.5) (15min/cont.)}*		
DBC 130S	2500	37 / 30 (49.6 / 40.2) (30min/cont.)	3028 (2234.7)	
DBC 130SL				

DBC II series

DBC 110 II

High-speed, high-performance spindle

Spindle Speed r/min	Spindle motor kW(Hp)	Torque N·m(ft·lbs)	
4000	26 / 22 (34.9 / 29.5) (30min/cont.)	2835 {3259, 3853}* (2092.2 {2405.1, 2843.5})*	
	{30 / 22 (40.2 / 29.5) (15min/cont.)		
	45 / 37 (60.3 / 49.6) (30min/cont.)*		

DBC 130 / L

High-power, high-torque spindle for heavy-duty machining

Spindle Speed r/min	Spindle motor kW(Hp)	Torque N·m(ft·lbs)	
2500	26 / 22 (34.9 / 29.5) (30min/cont.)	3383 {3940, 3703}* (2496.7 {2907.7, 2732.8})*	
	{30 / 22 (40.2 / 29.5) (15min/cont.)		
	45 / 37 (60.3 / 49.6) (30min/cont.)*		

DBC 250 / L II

High-speed, high-precision built-in Quill spindle

- Powerful Quill (Ø250mm) feed system (W-axis travel distance: 500 mm)
- Greased-type lubrication for the spindle bearings
- Stable thermal error of the spindle over a long-term operation

Spindle Speed r/min	Spindle motor kW(Hp)	Torque N·m(ft·lbs)	
6000	30 / 22 (40.2 / 29.5) (30min/cont.)	600 (442.8)	

Spindle Power – Torque Diagram

The powerful spindle motor further improves productivity.

DBC series

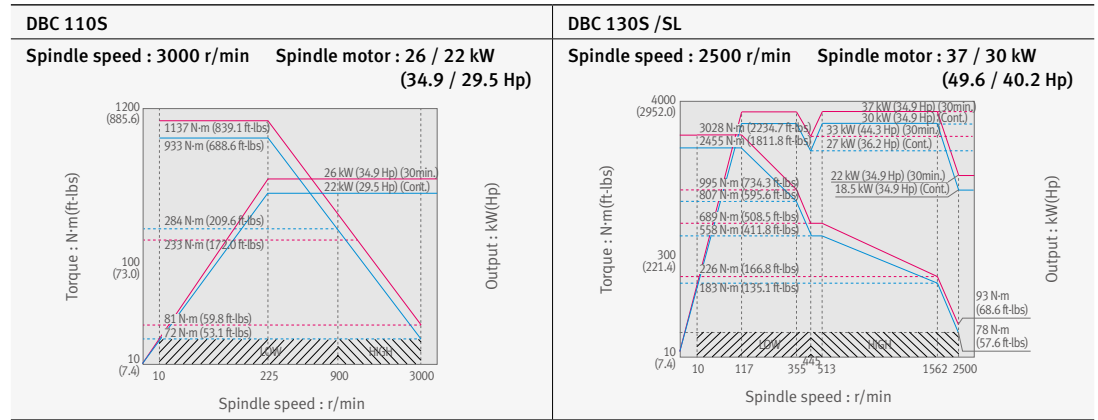

DBC II series

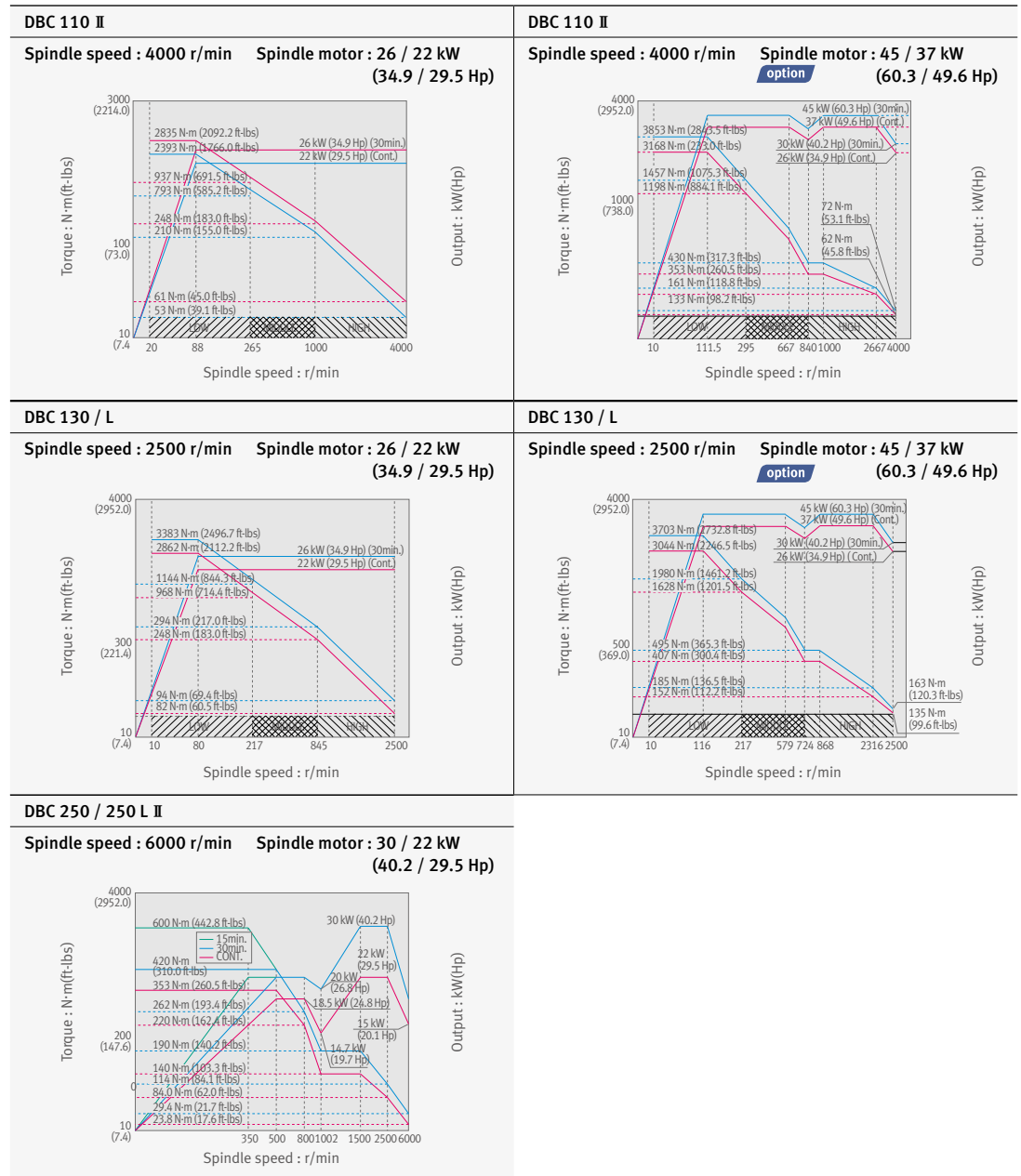

Basic Information

Diverse Line-up
High-Rigidity &
High-Precision
User Convenience

Detailed Information

Options
Capacity Diagram
Specifications

Customer Support Service



Enhanced Performance through High Rigid structure

Together with further improved high-rigidity structure and stabilized travel performance achieved through structure analysis, many options are upgraded to enhance user convenience

Optimal Solutions

 **Highly-Rigid Structure**

For heavier workpieces and higher processing quality, the design has been improved with a cast structure offering excellent stiffness. The machine performance has been further upgraded by structural analysis of the inner rib structure.

 **High Accuracy**

Upgraded with stable travel performance in heavy-duty machining by reducing servo load and increasing axial thrust.

 **High Productivity and User Convenience**

Diversified options are offered to improve productivity, operating environment and operator's convenience.



Highly-Rigid Structure

For heavier workpieces and higher processing quality, the design has been improved with a cast structure offering excellent stiffness. The machine performance has been further upgraded by structural analysis of the inner rib structure.

Highly Rigid Design of Major Units

Rigidity is enhanced by optimal design of the machine structure. The highest accuracy can be achieved by minimizing deformation caused by heavy load.



Stable Machine Structure

A highly-rigid, stable machine structure has been realized by optimizing the design of the column and the bed. Excellent wear resistance and accuracy for machining quality have been achieved by precision grinding after heat treatment.

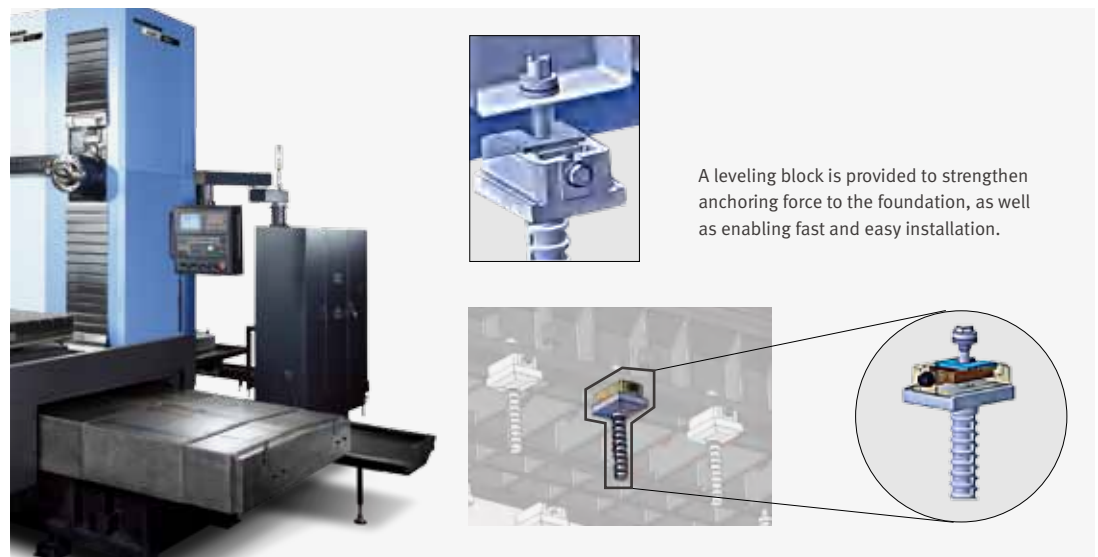

Narrow Guide System

Designed with narrow guide system to minimize axis torque and ensure smooth motion.

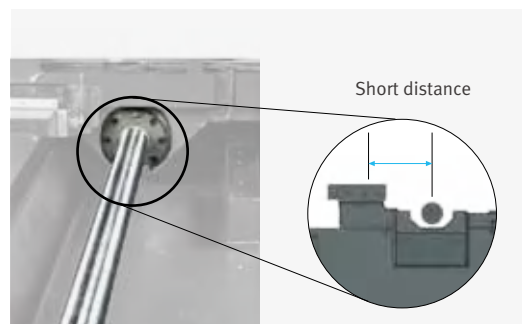

* Excluding the X axes of DBC 110S / 110 II / 130S / 130SL

4-row Angular Ball Bearings & Ball Screw

Both ends of the shafts are supported by 4-row angular contact bearings. Low-noise, highly-precise ball screws are employed for axis travel.

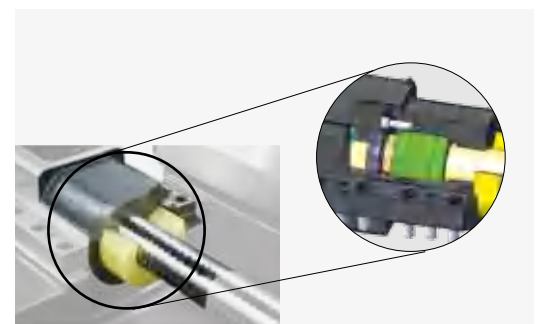

* Except DBC 110S / 130S (3-row angular contact bearings)



High Accuracy

Basic Information

Diverse Line-up
High-Rigidity &
High-Precision
User Convenience

Detailed Information

Options
Capacity Diagram
Specifications

Customer Support Service

Upgraded with stable travel performance in heavy-duty machining by reducing servo load and increasing axial thrust.

Rotary Table * Patented

A high-precision, separate type encoder is installed at the table center as a standard to realize precise rotation of the B-axis.



Locating pin for positioning by 90° steps

Gear reducer for axis shafts (X / Z)

- Servo load is reduced to secure stable feeding characteristics for heavy workpieces (X-axis).
- Axial thrust is increased to improve cutting capacity (Z-axis).

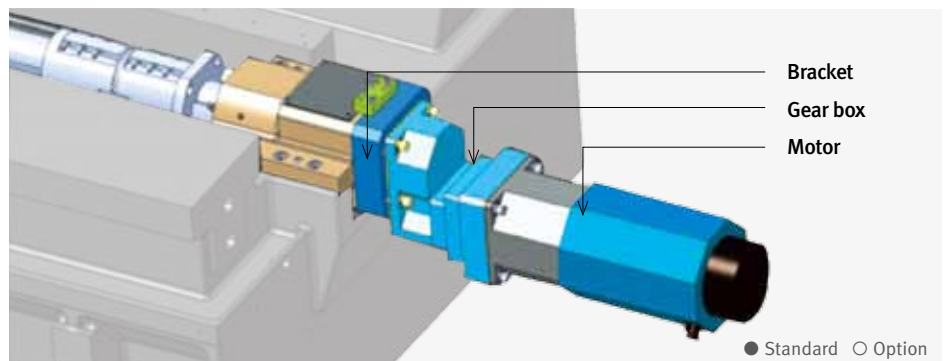

Bracket
Gear box
Motor

● Standard ○ Option

Axis \ Model	DBC 110S	DBC 130S	DBC 130SL	DBC 110 II	DBC 130 II	DBC 130L II	DBC 250 II	DBC 250L II
X-axis	○	○	○	○	○	●	○	●
Z-axis	○	○	○	○	○	●	○	●

ATC Auto Tool Changer (ATC)

The adoption of a servo-motor for tool magazine and carriage drive greatly reduces hydraulic system load of the entire machine. Machine has been improved by simplifying the structure to minimize the causes of failure.

Servo-driven Auto Tool Changer



Applicable Tool Specification

	Specification	Shape
Max. tool dia.	Normal tools: D = ϕ 130 mm (5.1 inch)	
	Facing tools: D = ϕ 250 mm (9.8 inch) (Neighboring pots must be empty)	
	Boring tools: D = ϕ 400 mm (15.7 inch) D = ϕ 600 mm (23.6 inch) option (Neighboring pots must be empty)	

	Specification	Shape
Max. tool length	L = 600 mm (23.6 inch)	
Max. tool weight	W = 25 kg (55.1 lb) W = 30 kg (66.1 lb) option	
Tool storage capacity	40 {60 / 90} tools option	

Max. allowable moment: 34 N·m (25.1 ft·lbs)

* Please contact us if you wish to extend the boring tool diameter (D= ϕ 600).

APC Automatic Pallet Changer (APC) **option**

While the machine tool is cutting a workpiece, the workpiece to be processed next is set up on the standby pallet which can replace the current pallet automatically at the end of cutting to raise productivity.

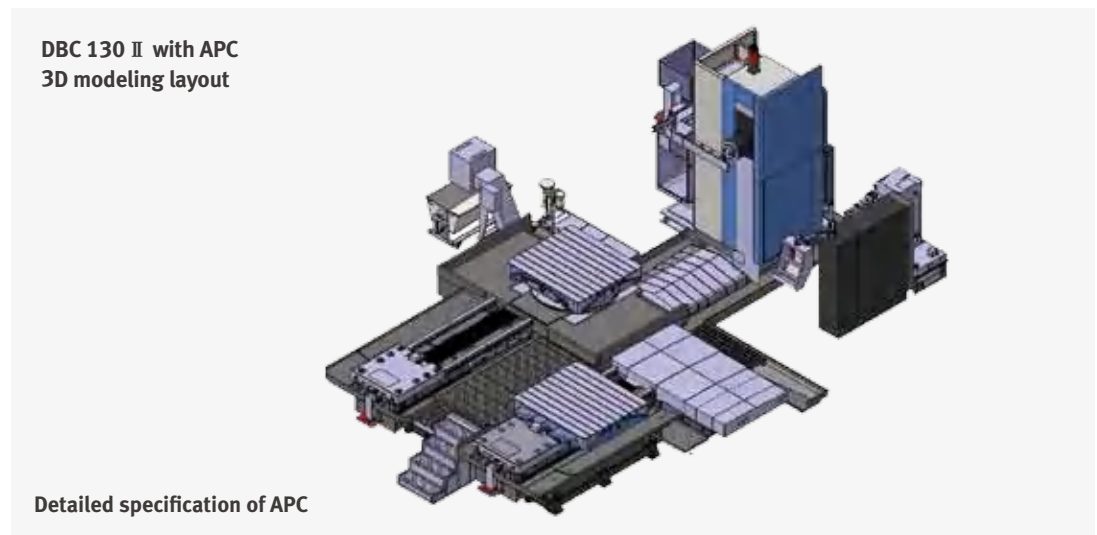

Details	Unit	Specification
No. of Pallets	ea	2
APC type	-	Parallel shuttle (in Z-axis direction)
Pallet size (W x L) & work load	mm (inch) & ton	<ul style="list-style-type: none"> • 1600 x 1800 & 10 (23.6 x 63.0 & 10) • 1800 x 2000 & 8 (70.9 x 78.7 & 8)

Note 1) The above specification is for reference to understand the APC option of DBC 130 II.

Note 2) Please contact us for further details of the specifications. The specifications are subject to change without prior notice for performance improvement



Chip Disposal System

Basic Information

Diverse Line-up
High-Rigidity &
High-Precision
User Convenience

Detailed Information

Options
Capacity Diagram
Specifications

Customer Support Service

Proper chip disposal is very important for productivity and environment protection. The DBC series provides various chip disposal systems designed to improve productivity and the working environment.

Easy Chip Removal Structure

The DBC series confines chips and coolant to the chip pan to make the chip disposal using the chip conveyor easier.



Coolant gun option



Chip pan

Slope-type chip pan is used for smooth coolant drain and chip disposal



Built-in, hinge-type belt chip conveyor



Lift-up chip conveyor option



Coolant Splash Guard option

Semi-splash guard

DBC 110S / 130S



DBC 130SL



DBC 110 II



DBC 130 / L
DBC 250 / L II



Auto door semi-splash guard (for APC option)

DBC 130 / L II
DBC 250 / L II

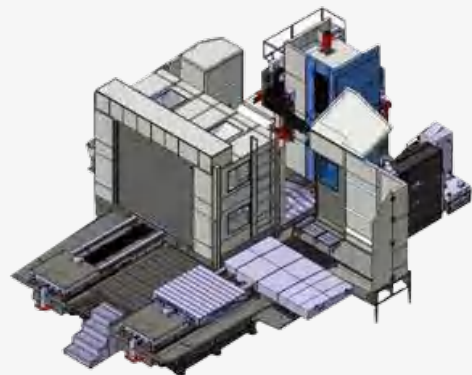

Special Options option

Following special options are available on order:

<p>1. Angle head (manual indexing) (L=365mm (14.4 inch))</p> 	<p>2. Long type angle head (manual indexing) (L=660mm (26.0 inch))</p> 	<p>3. Universal head (manual indexing)</p> 															
<p>4. Face plate (manual indexing) (Ø650mm (25.6 inch))</p> 	<p>5. Indexable angle head (90° auto indexing) Please contact us for further details of specification.</p> 	<p>6. Spindle support *</p> <ul style="list-style-type: none"> • DBC 110S / 110 II : L = 200mm (7.9 inch) • DBC 130S / SL : L = 310mm (12.2 inch) • DBC 130 / L : L = 310mm (12.2 inch) 															
<p>7. Facing head (Cogsdill) - Manual installation (For more details, please contact us.)</p> 	<p>8. Angle plate (4 types)</p> <ul style="list-style-type: none"> • Please contact us for customized specifications. • Please contact us for further information. <p style="text-align: right;">Unit : mm (inch)</p> <table border="1" style="width: 100%; border-collapse: collapse;"> <tbody> <tr> <td style="text-align: center;">A</td> <td style="text-align: center;">450 (17.7)</td> <td style="text-align: center;">500 (19.7)</td> <td style="text-align: center;">750 (29.5)</td> <td style="text-align: center;">750 (29.5)</td> </tr> <tr> <td style="text-align: center;">B</td> <td style="text-align: center;">600 (23.6)</td> <td style="text-align: center;">1000 (39.4)</td> <td style="text-align: center;">1250 (49.2)</td> <td style="text-align: center;">2000 (78.7)</td> </tr> <tr> <td style="text-align: center;">C</td> <td style="text-align: center;">400 (15.7)</td> <td style="text-align: center;">550 (21.7)</td> <td style="text-align: center;">750 (29.5)</td> <td style="text-align: center;">1000 (39.4)</td> </tr> </tbody> </table> 		A	450 (17.7)	500 (19.7)	750 (29.5)	750 (29.5)	B	600 (23.6)	1000 (39.4)	1250 (49.2)	2000 (78.7)	C	400 (15.7)	550 (21.7)	750 (29.5)	1000 (39.4)
A	450 (17.7)	500 (19.7)	750 (29.5)	750 (29.5)													
B	600 (23.6)	1000 (39.4)	1250 (49.2)	2000 (78.7)													
C	400 (15.7)	550 (21.7)	750 (29.5)	1000 (39.4)													

* Please consult us for employing ATC with spindle support attached.
(Note) The head attachments (1 ~ 7) are not applicable for DBC 250 (L) II model.



Easy and Convenient Operation

Operating system for enhanced user convenience

Basic Information

Diverse Line-up
High-Rigidity &
High-Precision
User Convenience

Detailed Information

Options
Capacity Diagram
Specifications

Customer Support Service



DOOSAN's new operation panel

With differentiated hotkey, the DBC Series enables fast access to frequently used functions

Conventional type Improved type

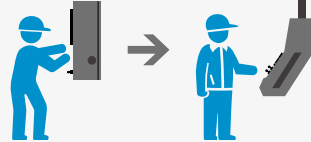

Improved user convenience with ergonomic design

The tilting operation panel ensures enhanced operating convenience.

Productivity improved by adoption of operator panel design optimized for the operation of large machines

- Mono lever jog switches are provided at the bottom of the main operation panel for easy traverse on the long axis of large machines (standard).
- Pulse handle for the operator's convenience and portable MPG for easy workpiece setting are provided as standard features.

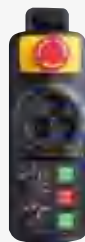

Portable MPG

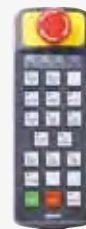

ATC OP panel



3 Portable MPG
option



MPG with LCD display
option



Mono lever jog switch

Easy Operation Package

Tool Load Monitoring

- Automatically detects tool wear and tear in the case of abnormal workloads using M-code.
- Workpiece-specific machining data can be saved.



Periodic Inspection Function

This function updates the operator with maintenance-related information such as oil refill timing.

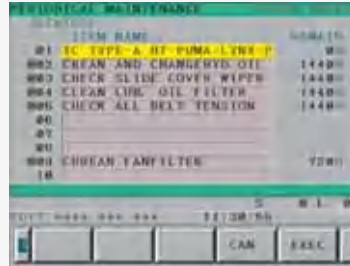

Automatic Backlash Compensation

After setting up the workpiece, feed backlash is automatically detected and compensated by the G-code instruction or through the function screen.



Tool Life Management

Tools are protected from abnormal load on the servo shaft, by skipping the tool or generating a freehold alarm.



Easy Pattern Cycle

Major processing pattern cycles and programs can be created by simply entering major factors. This function is built in the CNC, thus drastically reducing programming time and enabling easy use on site. A total of 22 patterns including basic 5 patterns are provided.



Drilling pattern



End-mill pattern

Variable Work Load Control[®]

When the operator enters the M-code for the weight of the workpiece, the system automatically determines the table feed pattern to perform cutting. Standard Option

M-Code	Work Load Control	DBC 110S	DBC 130S / SL	DBC 110 II	DBC 130 II	DBC 130L II	DBC 250 / L II
M380	5tons or less	●	●	●	●	●	●
M381	10tons or less	●	●	●	●	●	●
M382	15tons or less				●	●	●
M383	20tons or less					○	

Selection Function

Easy Set-up Guidance Touch Sensor (including OMP60) option

This function enables the simple setting up of workpiece coordinates, using an automatic or semi-automatic measuring probe. When using an auto-measuring probe, place the probe close to the set up surface, select the setup configuration, and press the cycle start button. The system touches the point and sets the workpiece coordinates automatically.



Support Function for Maintenance - Easy Operation Guidance option

Machine faults including problems with the ATC magazine are detected and troubleshooting suggestions are proposed for corrective action. For guidance on easy operation, display windows - including function selection, thermal error setting, program progress display, and operation report display - are provided.

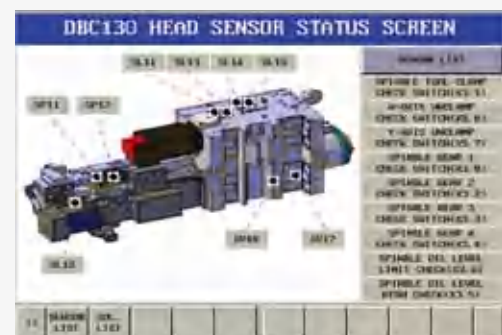

Standard / Optional Specifications

Various options are available to satisfy the customers' requirements.

Basic Information

Diverse Line-up
High-Rigidity &
High-Precision
User Convenience

Detailed Information

Options
Capacity Diagram
Specifications

Customer Support Service

DBC S series

● Standard ○ Optional X Not applicable

NO.	Description	Features	DBC 110S	DBC 130S	DBC 130SL
1	SPINDLE MOTOR POWER	26 / 22 KW (34.9 / 29.5 Hp) (30WORKPIECE SETTING DEVICE)	●	X	X
2		30 / 22 KW (40.2 / 29.5 Hp) (15WORKPIECE SETTING DEVICE) (AMP UP)	○	X	X
3		45 / 37 KW (60.3 / 49.6 Hp) (30WORKPIECE SETTING DEVICE)	X	X	X
4		37 / 30 KW (49.6 / 40.2 Hp) (30WORKPIECE SETTING DEVICE)	X	●	●
5	ATC	40 TOOLS	○	○	○
6		60 / 90 TOOLS	○	○	○
7	WORKPIECE SETTING DEVICE	CENTER BUSH	X	X	X
8		EDGE LOCATOR	○	○	○
9	TABLE SIZE	1400 X 1600 mm(55.1X63.0 inch)	●	●	X
10		1400 X 1800 mm(55.1X70.9 inch)	X	X	●
11		1600 X 1800 mm(63.0X70.9 inch)	X	X	X
12		1800 X 2000 mm(70.9X78.7 inch)	X	X	X
13		2000 X 2200 mm(78.7X86.6 inch)	X	X	X
14		1800 X 2000 mm(70.9X78.7 inch)_20 ton	X	X	X
15		2000 X 2200 mm(78.7X86.6 inch)_19 ton	X	X	X
16		1600 X 3000 mm(63.0X118.1 inch)_20 ton	X	X	X
17	APC ⁽¹⁾		○	○	○
18	LINEAR SCALE (X / Y / Z)	ABSOLUTE	○	○	○
19	RAISED COLUMN ⁽¹⁾		○	○	○
20	SPLASH GUARD	SPLASH GUARD W/O TOP	○	○	○
21		AUTO DOOR SEMI GUARD ^{(1) (2)}	○	○	○
22	COOLANT TANK		○	○	○
23	LIFT UP CHIP CONVEYOR		○	○	○
24	Flood Coolant		○	○	○
25	TSC	1.5 KW (2.0 Hp)_ 2.0 MPA_BAG FILTER	○	○	○
26		1.5 KW(2.0 Hp)_ 2.0 MPA_CYCLON FILTER	○	○	○
27		5.5 KW(7.4 Hp)_ 7.0 MPA_DUAL BAG FILTER	○	○	○
28	OIL SKIMMER	BELT TYPE	○	○	○
29		DISK TYPE	○	○	○
30	COOLANT GUN		○	○	○
31	AIR GUN		○	○	○
32	AIR BLOWER		○	○	○
33	6-AXIS OPTION ⁽³⁾	1 AXIS_WIRE AND PIPING_HYD	○	○	○
34	AUTO WORKPIECE MEASURING DEVICE	OMP60_RENISHAW	○	○	○
35		RMP60_RENISHAW	○	○	○
36	MASTER TOOL FOR AUTO TOOL MEASUREMENT	CALIBRATION BLOCK	○	○	○
37	AUTO TOOL MEASURING DEVICE	TS27R_RENISHAW	○	○	○
38	ANGULAR FIXTURE	SIZE 450 X 600 X 400	○	○	○
39		SIZE 500 X 1000 X 550	○	○	○
40		SIZE 750 X 1250 X 750	○	○	○
41		SIZE 1000 X 2000 X 1000	○	○	○
42	ATTACHMENT	90° ANGLE HEAD_L365	○	○	○
43		90° ANGLE HEAD_L660	○	○	○
44		FACE PLATE_Ø650	○	○	○
45		INDEXABLE ANGLE HEAD_90° INDEX	○	○	○
46		MANUAL UNIVERSAL HEAD_1000	○	○	○
47		SPINDLE SUPPORT_310 MM	X	○	○
48		SPINDLE SUPPORT_200 MM	○	X	X
49		COGSDILL READY	○	○	○
50	ATTACHMENT SPEED LIMIT CONTROL		○	○	○
51	ATTACHMENT SPEED LIMIT CONTROL		○	○	○
52	THERMAL DISPLACEMENT OF SPINDLE		○	○	○
53	TEST BAR	BT50	○	○	○
54	Y-AXIS ADDITIONAL BRAKE SYSTEM ⁽¹⁾		○	○	○
55	NC SCREEN SIZE	10.4 INCH(COLOR)	●	●	●
56		15.0 INCH(COLOR)	○	○	○
57	GRAVITY SHAFT FALL PREVENTION SYSTEM (AT POWER FAILURE)		○	○	○
58	TRANSFORMER		○	○	○
59	POWER PANEL AIR CONDITIONER		○	○	○
60	POWER PANEL LIGHT		○	○	○
61	POWER PANEL LINE FILTER		○	○	○
62	AUTO NC POWER OFF		○	○	○
63	AUTO NC POWER ON		○	○	○
64	MACHINE WARMING UP		○	○	○
65	DOOSAN TOOL MANAGEMENT PACKAGE		○	○	○
66	DOOSAN TOOL LOAD MONITORING		○	○	○
67	MPG	1 MPG_PORTABLE_W/ENABLE TYPE	●	●	●
68		3 MPG_PORTABLE_W/ENABLE TYPE	○	○	○
69	ALARM GUIDANCE		○	○	○
70	EASY SETUP GUIDANCE		○	○	○
71	COUNTER FUNCTION	WORK/TOTAL/DAILY	○	○	○
	NC		32iB	0iMF	31iB
72	DSQ1 (200Block)		●	○	●
73	DSQ1 (400Block)		○	○	○
74	DSQ2 (DSQ1+Data Server 1GB)		○	○	○
75	DSQ3 (DSQ2 + 600Block)		X	X	○
76	DSQ4 (DSQ3 + 1000Block)		X	X	○

* Note 1) Please contact us for further details

* Note 2) This specification applies to APC option.

* Note 3) 30 min/continuous For DBC 250(L)

DBC II series

● Standard ○ Optional X Not applicable

NO.	Description	Features	DBC 110 II	DBC 130 II	DBC 130L II	DBC 250 II	DBC 250L II
1	SPINDLE MOTOR POWER	26 / 22 KW(34.9 / 29.5 Hp) (30min/continuous)	●	●	●	X	X
2		30 / 22 KW(34.9 / 29.5 Hp) (15min/continuous) (AMP UP)	○	○	○	● ⁽³⁾	● ⁽³⁾
3		45 / 37 KW(34.9 / 29.5 Hp) (30min/continuous)	○	○	○	X	X
4		37 / 30 KW(34.9 / 29.5 Hp) (30min/continuous)	X	X	X	X	X
5	ATC	40 TOOLS	○	○	○	○	○
6		60 / 90 TOOLS	○	○	○	○	○
7	WORKPIECE SETTING DEVICE	CENTER BUSH	X	○	○	○	○
8		EDGE LOCATOR	○	○	○	○	○
9	TABLE SIZE	1400 X 1600 mm (55.1X63.0 inch)	X	X	X	X	X
10		1400 X 1800 mm (55.1X70.9 inch)	●	X	X	X	X
11		1600 X 1800 mm (63.0X70.9 inch)	X	●	●	●	●
12		1800 X 2000 mm (70.9X78.7 inch)	X	○	○	○	○
13		2000 X 2200 mm (78.7X86.6 inch)	X	○	○	○	○
14		1800 X 2000 mm (70.9X78.7 inch)_20 ton	X	X	○	X	X
15		2000 X 2200 mm (78.7X86.6 inch)_19 ton	X	X	○	X	X
16	1600 X 3000 mm (63.0X118.1 inch)_20 ton	X	X	X	X	X	
17	APC ⁽¹⁾		○	○	○	○	○
18	LINEAR SCALE (X, Y, Z-AXIS)	ABSOLUTE	○	○	○	●	●
19	RAISED COLUMN ⁽¹⁾		○	○	○	○	○
20	SPLASH GUARD	SPLASH GUARD W/O TOP	○	○	○	○	○
21		AUTO DOOR SEMI GUARD ^{(1) (2)}	○	○	○	○	○
22	COOLANT TANK		○	○	○	○	○
23	LIFT-UP CHIP CONVEYOR		○	○	○	○	○
24	Flood Coolant		○	○	○	○	○
25	TSC	1.5 KW_2.0 MPA_BAG FILTER	○	○	○	○	○
26		1.5 KW_2.0 MPA_CYCLON FILTER	○	○	○	○	○
27		5.5 KW_7.0 MPA_DUAL BAG FILTER	○	○	○	○	○
28	OIL SKIMMER	BELT TYPE	○	○	○	○	○
29		DISK TYPE	○	○	○	○	○
30	COOLANT GUN		○	○	○	○	○
31	AIR GUN		○	○	○	○	○
32	AIR BLOWER		●	○	○	●	●
33	6-AXIS OPTION ⁽¹⁾	1 AXIS_WIRE AND PIPING_HYD	○	○	○	○	○
34	AUTO WORK MEASURING DEVICE	OMP60_RENISHAW	○	○	○	○	○
35		RMP60_RENISHAW	○	○	○	○	○
36	MASTER TOOL FOR AUTO TOOL MEASUREMENT	CALIBRATION BLOCK	○	○	○	○	○
37	AUTO TOOL MEASURING DEVICE	TS27R_RENISHAW	○	○	○	○	○
38	ANGULAR FIXTURE	SIZE 450 X 600 X 400	○	○	○	○	○
39		SIZE 500 X 1000 X 550	○	○	○	○	○
40		SIZE 750 X 1250 X 750	○	○	○	○	○
41		SIZE 1000 X 2000 X 1000	○	○	○	○	○
42	ATTACHMENT	90° ANGLE HEAD_L365	○	○	○	X	X
43		90° ANGLE HEAD_L660	○	○	○	X	X
44		FACE PLATE_Ø650	○	○	○	X	X
45		INDEXABLE ANGLE HEAD_90° INDEX	○	○	○	X	X
46		MANUAL UNIVERSAL HEAD_1000	○	○	○	X	X
47		SPINDLE SUPPORT_310 MM	X	○	○	X	X
48		SPINDLE SUPPORT_200 MM	○	X	X	X	X
49	COGSDILL READY	○	○	○	X	X	
50	ATTACHMENT SPEED LIMIT CONTROL		○	○	○	X	X
51	SAFETY FENCE AND INTERLOCK SWITCH		○	○	○	○	○
52	CORRECTION OF SPINDLE'S THERMAL DISPLACEMENT		○	○	○	X	X
53	TEST BAR	BT50	○	○	○	○	○
54	Y-AXIS ADDITIONAL BRAKE SYSTEM ⁽¹⁾		○	○	○	○	○
55	NC SCREEN SIZE	10.4 INCH(COLOR)	●	●	●	●	●
56		15.0 INCH(COLOR)	○	○	○	○	○
57	GRAVITY SHAFT FALL PREVENTION SYSTEM (AT POWER FAILURE)		○	○	○	○	○
58	TRANSFORMER		○	○	○	○	○
59	POWER PANEL AIR CONDITIONERPOWER PANEL AIR CONDITIONER		○	○	○	○	○
60	POWER PANEL LIGHT		○	○	○	○	○
61	POWER PANEL LINE FILTER		○	○	○	○	○
62	AUTO NC POWER OFF		○	○	○	○	○
63	AUTO NC POWER ON		○	○	○	○	○
64	MACHINE WARMING UP		○	○	○	○	○
65	DOOSAN TOOL MANAGEMENT PACKAGE		○	○	○	○	○
66	DOOSAN TOOL LOAD MONITORING		○	○	○	○	○
67	MPG	1 MPG_PORTABLE_W/ENABLE TYPE	●	●	●	●	●
68		3 MPG_PORTABLE_W/ENABLE TYPE	○	○	○	○	○
69	ALARM GUIDANCE		○	○	○	○	○
70	EASY SETUP GUIDANCE		○	○	○	○	○
71	COUNTER FUNCTION	WORK/TOTAL/DAILY	○	○	○	○	○
	NC		31iB	31iB	31iB		31iB
72	DSQ1 (200Block)		●	●	●		●
73	DSQ1 (400BLOCK)		○	○	○		○
74	DSQ2 (DSQ1+Data Server 1GB)		○	○	○		○
75	DSQ3 (DSQ2 + 600Block)		○	○	○		○
76	DSQ4 (DSQ3 + 1000Block)		○	○	○		○

External Dimensions

Basic Information

Diverse Line-up
High-Rigidity &
High-Precision
User Convenience

DBC 110S

Unit: mm(inch)

Detailed Information

Options
Capacity Diagram
Specifications

Customer Support Service

Top View

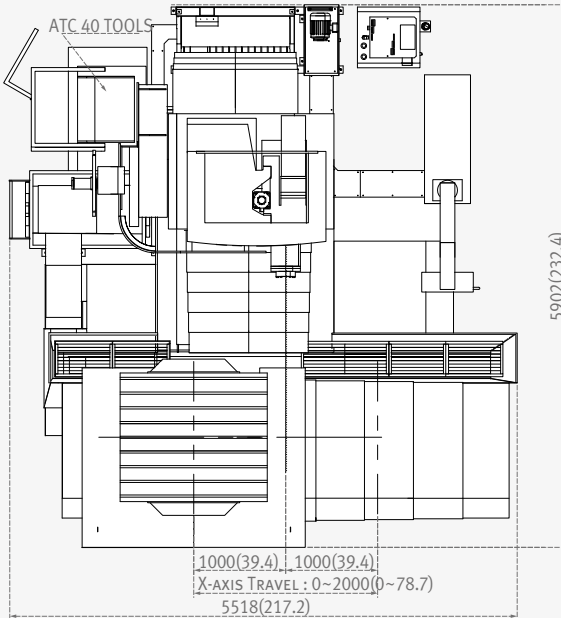

Front View

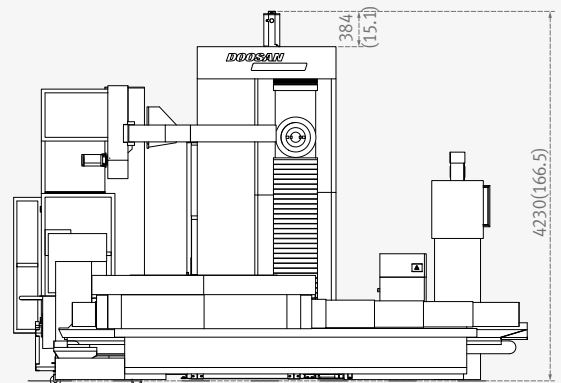

Side View

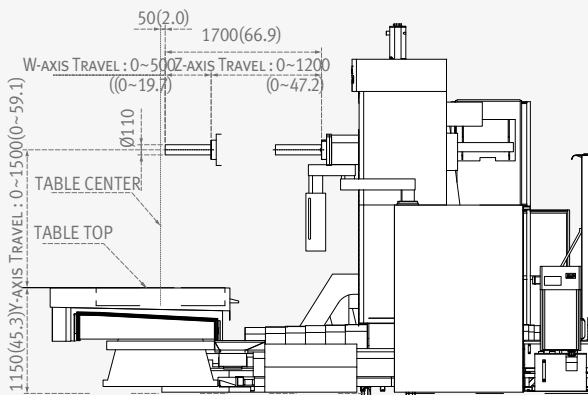

Table

1400 x 1600 (55.1 x 63.0)

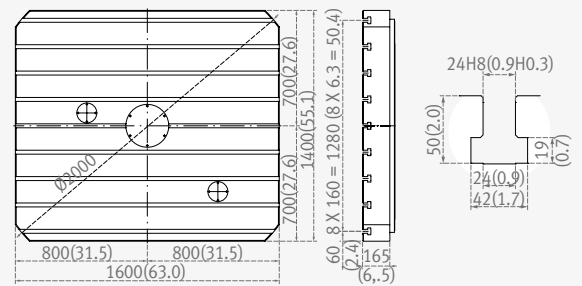

External Dimensions

DBC 130S

Unit: mm(inch)

Top View

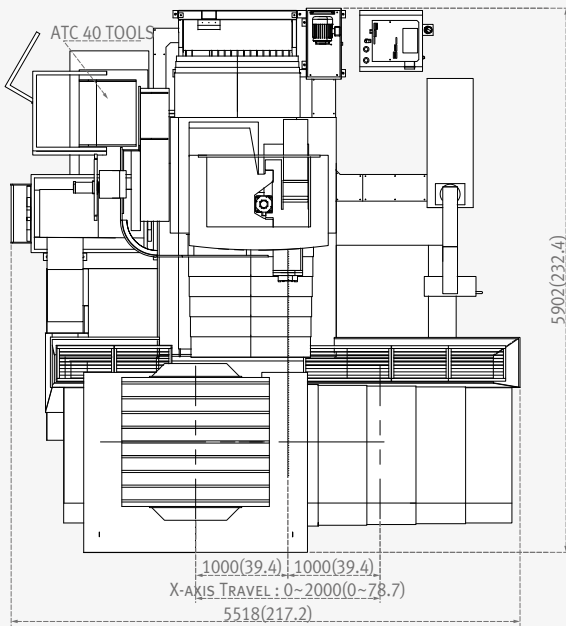

Front View

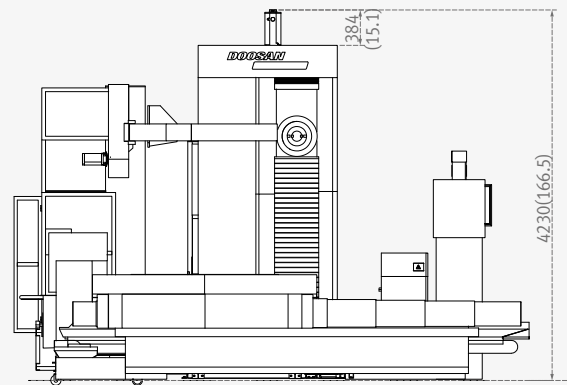

Side View

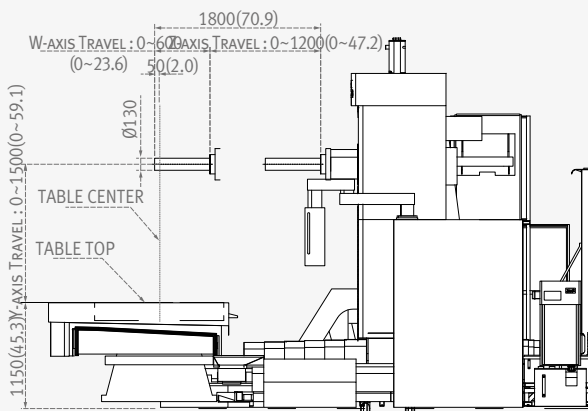

Table

1400 x 1600 (55.1 x 63.0)

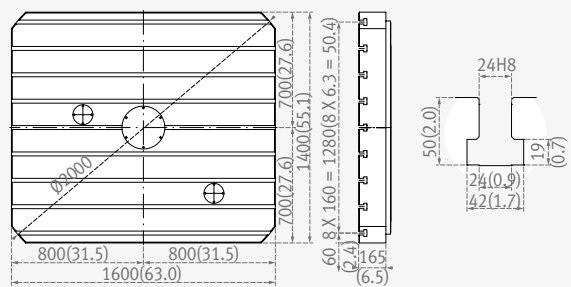

External Dimensions

Basic Information

Diverse Line-up
High-Rigidity &
High-Precision
User Convenience

Detailed Information

Options
Capacity Diagram
Specifications

Customer Support Service

DBC 130 SL

Unit: mm(inch)

Top View

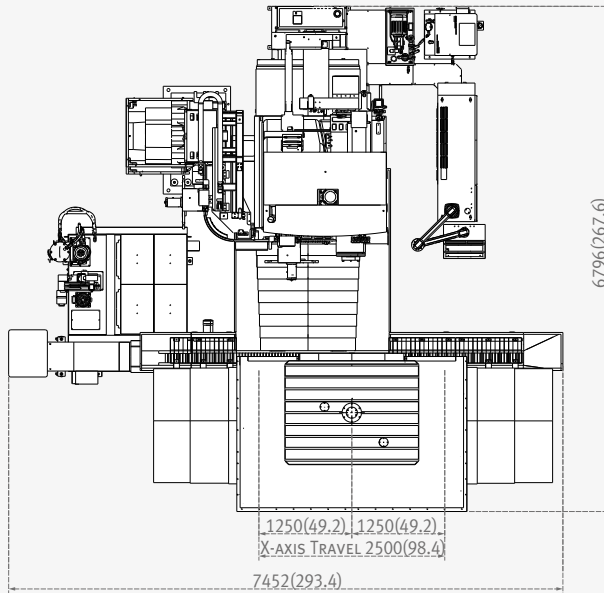

Front View

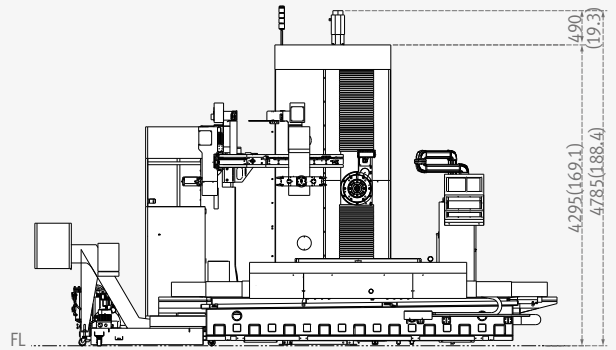

Side View

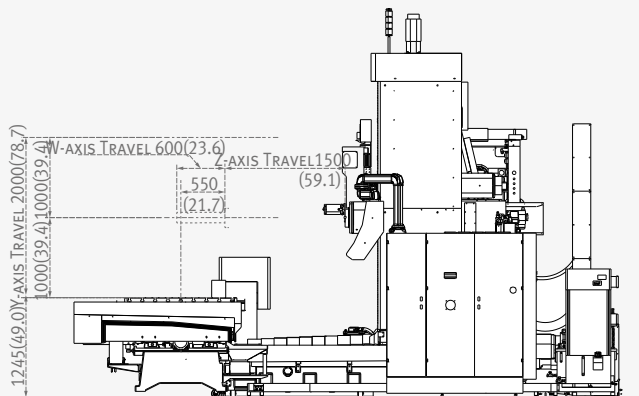

Table

1400 x 1800 (55.1 x 70.9)

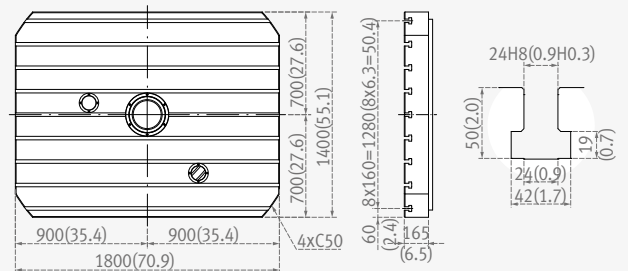

External Dimensions

DBC 110 II

Unit: mm(inch)

Top View

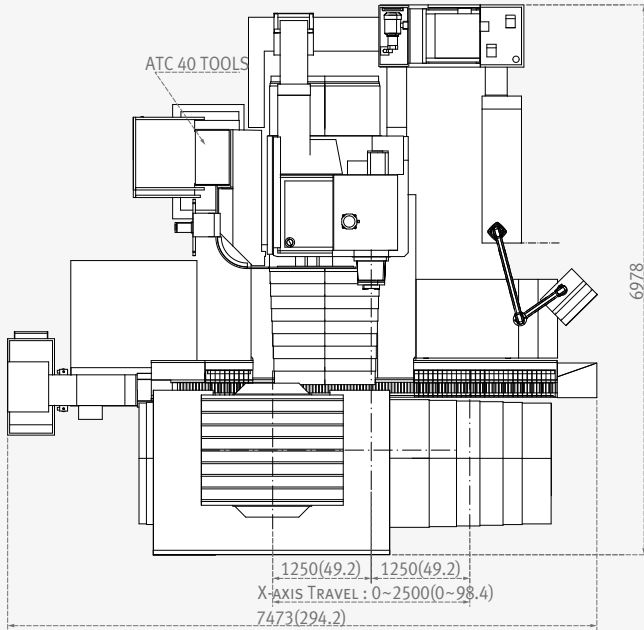

Front View

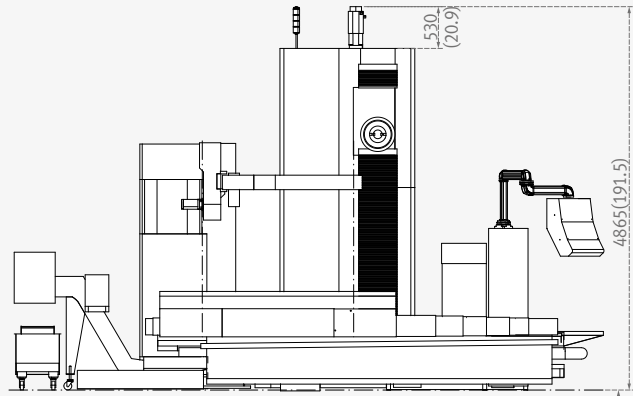

Side View

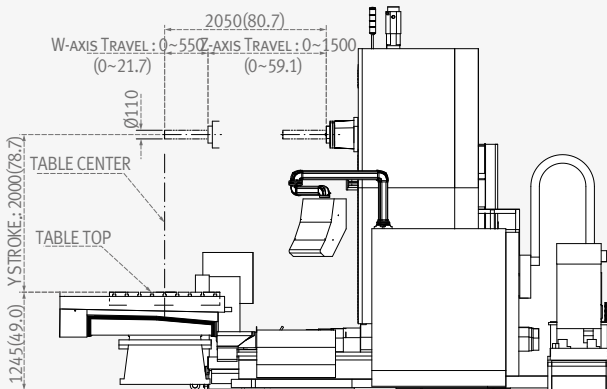

Table

1400 x 1600 (55.1 x 63.0)

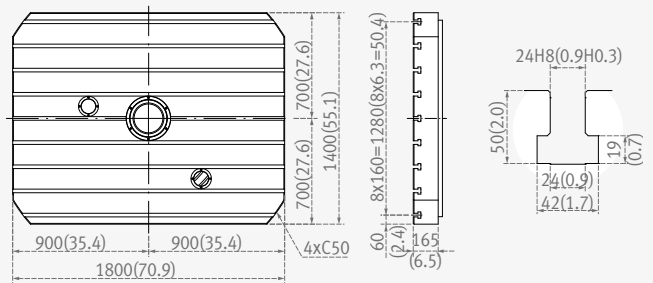

External Dimensions

Basic Information

Diverse Line-up
High-Rigidity &
High-Precision
User Convenience

Detailed Information

Options
Capacity Diagram
Specifications

Customer Support Service

DBC 130 / L DBC 250 / L II

Unit: mm(inch)

Top View

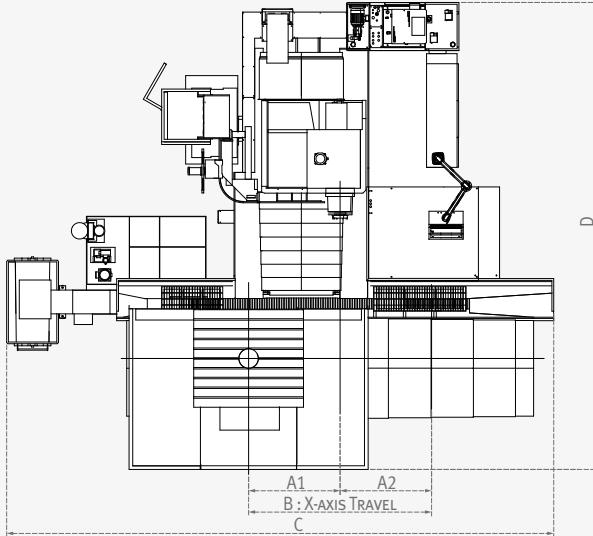

Front View

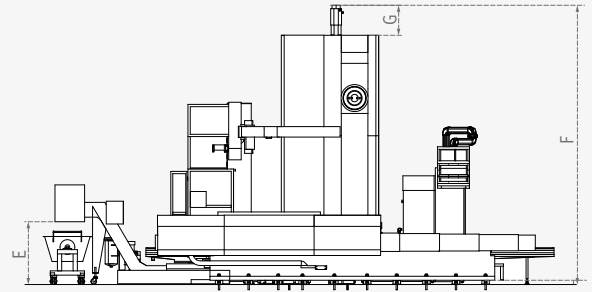

DBC 130 / L

Side View

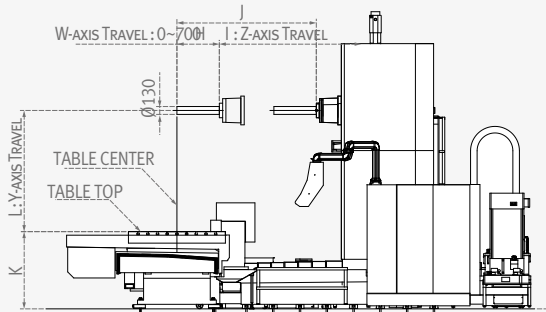

DBC 250 / L II

Side View

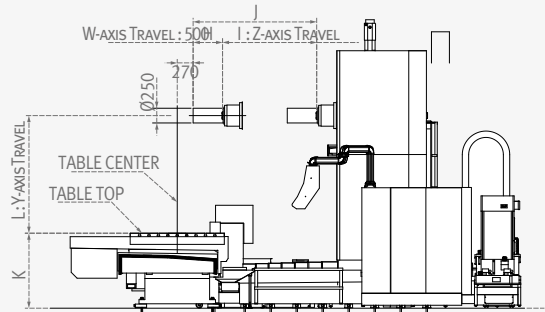

Machine	A1 / A2	B	C	D	E	F	G	H	I	J	K	L
DBC 130 II	1500 (59.1)	0-3000 (0-118.1)	8970 (353.1)	7660 (301.6)	1103 (43.4)	4905 (193.1)	527 (20.7)	0-700 (0-27.6)	0-1600 (0-63.0)	2300 (90.6)	1275 (50.2)	0-2000 (0-78.7)
DBC 130L II	2000 (78.7)	0-4000 (0-157.5)	9970 (392.5)	8085 (318.3)	1103 (43.4)	5406 (212.8)	527 (20.7)	0-700 (0-27.6)	0-2000 (0-78.7)	2700 (106.3)	1275 (50.2)	0-2500 (0-98.4)
DBC 250 II	1500 (59.1)	0-3000 (0-118.1)	8970 (353.1)	7660 (301.6)	1103 (43.4)	4905 (193.1)	527 (20.7)	0-500 (0-19.7)	0-1600 (0-63.0)	2100 (82.7)	1275 (50.2)	0-2000 (0-78.7)
DBC 250L II	2000 (78.7)	0-4000 (0-157.5)	9970 (392.5)	8085 (318.3)	1103 (43.4)	5406 (212.8)	527 (20.7)	0-500 (0-19.7)	0-2000 (0-78.7)	2500 (98.4)	1275 (50.2)	0-2500 (0-98.4)

External Dimensions

DBC 130 II with APC option

Unit: mm(inch)

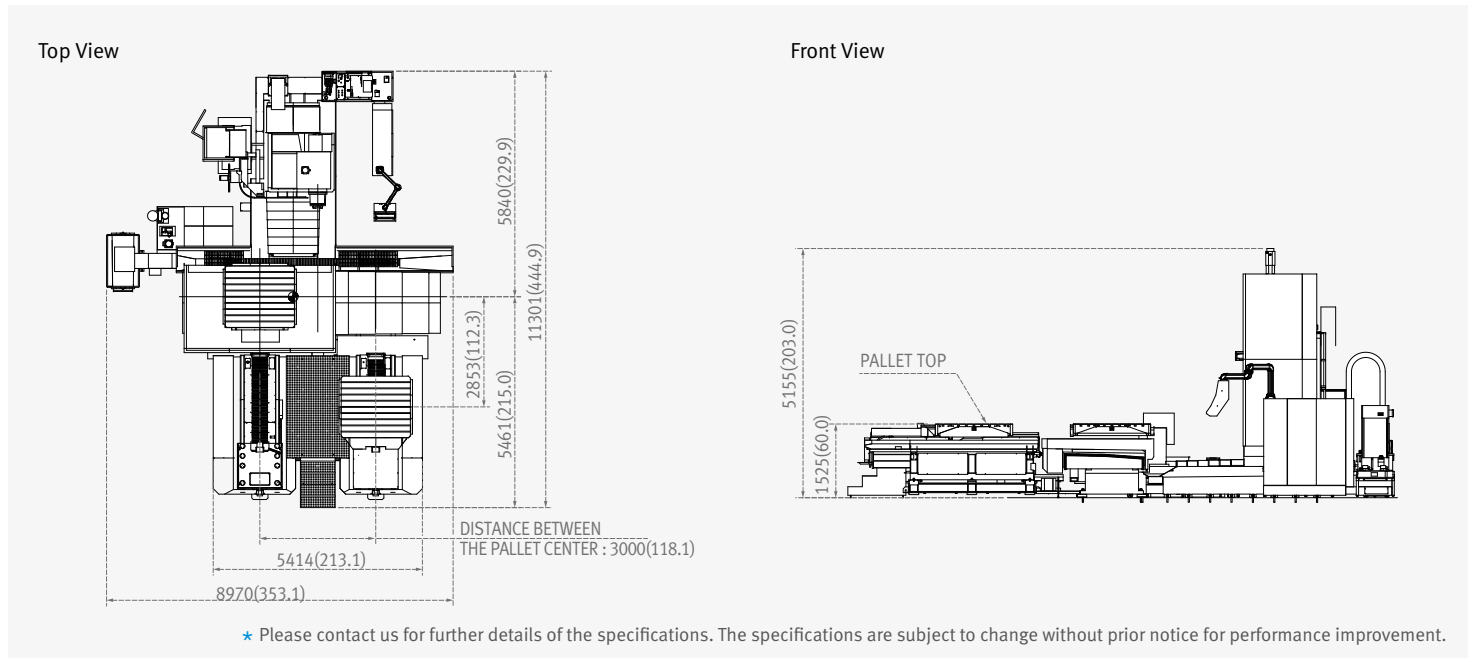

APC Pallet

T-Slot

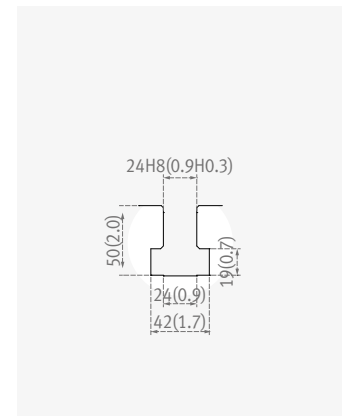
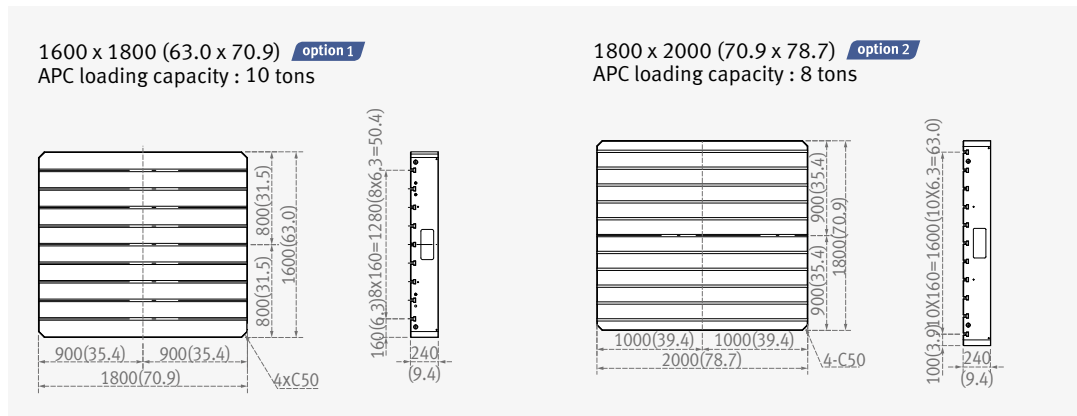

Table

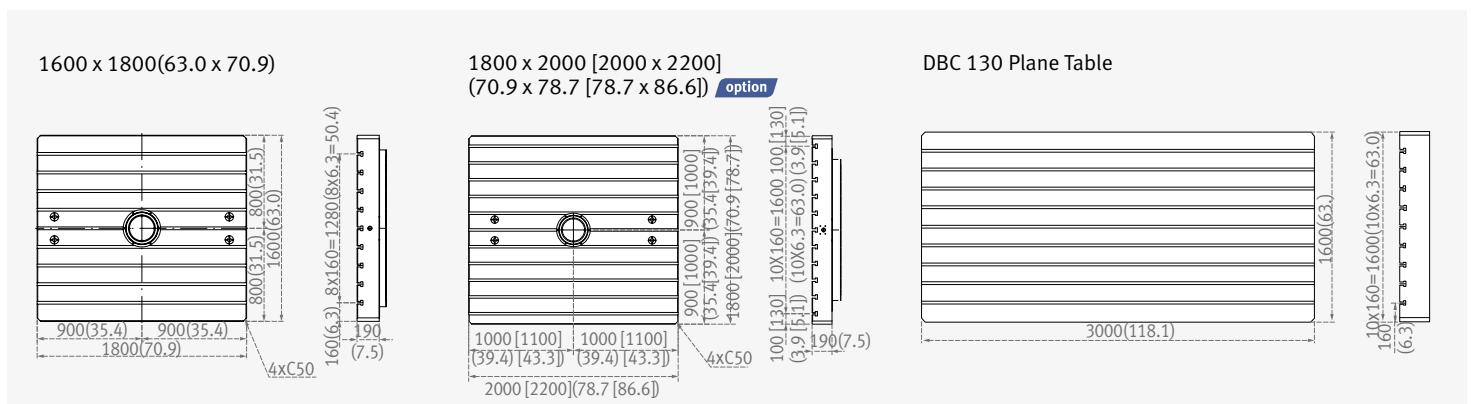

Machine Specifications

Basic Information

Diverse Line-up
High-Rigidity &
High-Precision
User Convenience

Detailed Information

Options
Capacity Diagram
Specifications

Customer Support Service



Description		Unit	DBC 110S	DBC 130S	DBC 130SL	
Travels	Travel distance	X-axis	2000 (78.7)		2500 (98.4)	
		Y-axis	1500 (59.1)		2000 (78.7)	
		Z-axis	1200 (47.2)		1500 (59.1)	
	W-axis	500 (19.7)	600 (23.6)			
	Distance from spindle nose to table top	mm (inch)	0 ~ 1500 (0~59.1)		0~2000 (0~78.7)	
Distance from spindle nose to table center	mm (inch)	550 ~ 1750 (21.7~2.9)				
Feedrate	Rapid traverse	X, Y, Zaxes	12			
		W-axis	6			
	Cutting feedrate	X, Y, Zaxes	1 ~ 6000			
Table	Table size		1400 x 1600 (55.1x63.0)		1400 x 1800 (55.1x70.9)	
	Swing diameter	Without semi-S/G	ø2550		ø3400	
		With semi-S/G	ø2100		ø2250	
	Load capacity	1400 x 1600 mm	kg (lb)	7000 (15432.1)	8000 {10000} (17636.7 {22045.9})	-
		1400 x 1800 mm	kg (lb)	-	-	22045.9
		1600 x 3000 mm	kg (lb)	-	-	-
		1600 x 1800 mm	kg (lb)	-	-	-
1800 x 2000 mm		kg (lb)	-	-	-	
2000 x 2200 mm	kg (lb)	-	-	-		
Spindle	Max. spindle speed		r/min	3000	2500	
	Max. spindle speed		mm (inch)	110	130	
	Quill diameter		mm (inch)	-	-	-
Motor	Spindle motor (30 min/cont.) {AMP UP: 15 min/cont.}		kW (Hp)	26 / 22(34.9 / 29.5) {30 / 22 (40.2 / 29.5)}*	37 / 30 (49.6 / 40.2)	
ATC option	Tool storage capacity		ea	40 / 60 / 90		
	Tool shank			MAS403 BT50		
	Max. tool diameter		mm (inch)	ø130 / 250 / 400 / 600 ⁽¹⁾		
	Max. tool length		mm (inch)	600		
	Max. tool weight		kg (lb)	25 (55.1) / 30 (66.1)		
	Method of tool selection			Fixed address		
Power source	Electric power supply (rated capacity)		kVA	70		
Machine dimensions	Height		mm (inch)	4230 (166.5)	4860 (191.3)	
	Length x Width		mm (inch)	5520 x 5900 (217.3 x 232.3)	7450 x 6800 (293.3 x 267.7)	
	Weight		kg (lb)	29000 (63933.1)	30000 (66137.7)	36000 (79365.2)
NC system			-	FANUC 32i	DOOSAN FANUC i	

* { } : Option

(1) For ø250 and ø400 mm tools, neighboring pots must be empty. For ø600 mm tools, neighboring two pots must be empty.

Machine Specifications



Description		Unit	DBC 110 II	DBC 130 II	DBC 130L II	DBC 250 II	DBC 250L II	
Travels	Travel distance	X-axis	mm (inch)	2500 (98.4)	3000 (118.1)	4000 (157.5)	3000 (118.1)	4000 (157.5)
		Y-axis	mm (inch)	2000 (78.7)		2500 (98.4)	2000 (78.7)	2500 (98.4)
		Z-axis	mm (inch)	1500 (59.1)	1600 (63.0)	2000 (78.7)	1600 (63.0)	2000 (78.7)
		W-axis	mm (inch)	550 (21.7)	700 (27.6)		500 (19.7)	500 (19.7)
	Distance from spindle nose to table top	mm (inch)	0 ~ 2000 (0~78.7)		0 ~ 2500 (0~98.4)	0 ~ 2000 (0~78.7)	0 ~ 2500 (0~98.4)	
Distance from spindle nose to table center	mm (inch)	550 ~ 1750 (21.7 ~ 68.9)	700 ~ 2300 (27.6 ~ 90.6)	700 ~ 2700 (27.6 ~ 106.3)	770 ~ 2370 (30.3 ~ 93.3)	770 ~ 2770 (30.3 ~ 109.1)		
Feedrate	Rapid traverse	X, Y, Zaxes	m/min	12	10	10 / 8 / 10 {7 / 8 / 10}*	10	10 / 8 / 10
		W-axis	m/min	6(0.2)			10	
	Cutting feedrate	X, Y, Zaxes	mm/min	1 ~ 6000	1 ~ 4000			
Table	Table size	mm (inch)	1400 x 1800 (55.1 x 70.9)	1600 x 1800 (63.0 x 70.9) {1800 x 2000 (70.9 x 78.7), 2000 x 2200 (78.7 x 86.6)}*		1600 x 1800 (63.0 x 70.9) {1800 x 2000 (70.9 x 78.7), 2000 x 2200 (78.7 x 86.6)}*		
	Swing diameter	Without semi-S/G	mm (inch)	Ø3400	Ø3900	Ø4800	Ø3900	Ø4800
		With semi-S/G	mm (inch)	Ø2250	Ø3400	Ø3400	Ø3400	Ø3400
	Load capacity	1400 x 1600 mm	kg (lb)	-	-	-	-	-
		1400 x 1800 mm	kg (lb)	10000 (22045.9)	-	-	-	-
		1600 x 3000 mm	kg (lb)	-	-	-	-	-
		1600 x 1800 mm	kg (lb)	-	15000 (3306.9)		15000 (3306.9)	
1800 x 2000 mm		kg (lb)	-	{13000 (28659.7)}*	{13000 (28659.7), 20000 (44091.8)}*	{13000 (28659.7)}*		
2000 x 2200 mm	kg (lb)	-	{12000 (26455.1)}*	{12000 (26455.1), 19000}*	{12000 (26455.1)}*			
Spindle	Max. spindle speed	r/min	4000	2500		6000		
	Boring spindle diameter	mm (inch)	110 (4.3)	130 (5.1)		-	-	
	Quill diameter	mm (inch)	-			250(9.8)		
Motor	Spindle motor (30 min/cont.) {AMP UP: 15 min/cont.}	kW (Hp)	26 / 22 {30 / 22}* , {45 / 37}*			30 / 22		
ATC <small>option</small>	Tool storage capacity	ea	40 / 60 / 90					
	Tool shank		MAS403 BT50					
	Max. tool diameter	mm	Ø130 / 250 / 400 / 600 ⁽¹⁾					
	Max. tool length	mm (inch)	600 (23.6)					
	Max. tool weight	kg (lb)	25 (55.1) / 30 (66.1)					
	Method of tool selection		Fixed address					
Power source	Electric power supply (rated capacity)	kVA	70 {90 kVA with 45kW motor}*			70		
Machine dimensions	Height	mm (inch)	4870 (191.7)	4910 (193.3)	5410 (213.0)	4910(193.3)	5410 (213.0)	
	Length x Width	mm (inch)	7470 x 6980 (294.1 x 274.8)	8970 x 7660 (353.1 x 301.6)	9970 x 8090 (392.5 x 318.5)	8970 x 7640 (353.1 x 300.8)	9970 x 8090 (392.5 x 318.5)	
	Weight	kg (lb)	36000 (79365.2)	43000 (94797.4)	48000 (105820.3) {50000}*	43000 (94797.4)	48000 (105820.3)	
NC system		-	FANUC 31i					

* { } : Option

(1) For Ø250 and Ø400 mm tools, neighboring pots must be empty. For Ø600 mm tools, neighboring two pots must be empty.

FANUC 31i

Basic Information

Diverse Line-up
High-Rigidity &
High-Precision
User Convenience

Detailed Information

Options
Capacity Diagram
Specifications

Customer Support Service

Control Axes

- Controlled axes	5 (X, Y, Z, W, B)
- Simultaneously controllable axes	
	Positioning(G00)/Linear interpolation(G01) : 3 axes Circular interpolation(G02, G03) : 2 axes
- Backlash compensation	
- Emergency stop / overtravel	
- Follow up	
- Least command increment	0.001mm / 0.0001(inch)
- Least input increment	0.001mm / 0.0001(inch)
- Machine lock	all axes / Z axis
- Mirror image	Reverse axis movement (setting screen and M - function)
- Stored pitch error compensation	Pitch error offset compensation for each axis
- Stored stroke check 1	Overtravel controlled by software

Interpolation & Feed Function

- 2nd reference point return	G30
- AI Contour Control II	200 block preview
- Automatic corner deceleration	
- Circular interpolation	G02, G03
- Control axis detach	
- Dual position feedback	
- Dwell	G04
- Exact stop check	G09, G61 (mode)
- Feed per minute	mm / min
- Feedrate clamp by circular radius	
- Feedrate override (10% increments)	0 - 200 %
- Helical interpolation	
- Jog feedrate	0~ 5000 mm/min
- Linear ACC/DEC after interpolation	
- Linear ACC/DEC before interpolation	
- Linear interpolation	G01
- Manual handle feed(1 unit)	
- Manual handle feedrate	0.1 / 0.01 / 0.001mm
- Override cancel	M48 / M49
- Positioning	G00
- Program restart	
- Rapid traverse bell-shaped acceleration / deceleration	
- Rapid traverse override	F0 (fine feed), 25 / 50 / 100 %
- Reference point return	G27, G28, G29
- Skip function	G31
- Smooth backlash compensation	
- Thread cutting, synchronous cutting	

Spindle & M-code Function

- M - code function	M 3 digits
- Polar coordinate interpolation	G12.1 / G13.1
- Retraction for rigid tapping	
- Rigid tapping	G84, G74
- Scaling	G50, G51
- Spindle orientation	
- Spindle output switching	
- Spindle serial output	
- Spindle speed command	S5 digits
- Spindle speed override (10% increments)	10 - 150 %

TOOL FUNCTION

- Cutter compensation C	G40, G41, G42
- Tool length compensation	G43, G44, G49
- Tool life management	
	Geometry / Wear and Length / Radius offset memory
- Tool number command	T3 digits
- Tool offset memory C	
- Number of tool offsets	200 ea

Programming & Editing Function

- Absolute / Incremental programming	G90 / G91
- Addition of custom macro common variables	
- Additional work coordinate system(48 Pair)	G54.1 P1 - 48 pairs
- Auto. Coordinate system setting	
- Background editing	
- Canned cycle	G73, G74, G76, G80 - G89, G99
- Circular interpolation by radius programming	
- Coordinate system rotation	G68, G69
- Custom macro B	
- Custom size 512kb	
- Decimal point input	
- Extended part program editing	
- I / O interface	USB / RS-232C
- Inch / metric conversion	G20 / G21

- Label skip	
- Local / Machine coordinate system G52 / G53	
- Macro executor	
- Maximum commandable value	±99999.999mm (±9999.9999 inch)
- No. of Registered programs	500 ea
- Optional angle chamfering / corner R	
- Optional block skip	
- Optional stop	M01
- Part program storage	256kb(640 m)
- Program number	O4-digits
- Program protect	
- Program stop / end	M00 / M02, M30
- Programmable data input	Tool offset and work offset are entered by G10, G11
- Sub program	Up to 4 nesting
- Tape code	ISO / EIA Automatic discrimination
- Work coordinate system	G54 - G59

OTHERS FUNCTIONS (Operation, Setting & Display, etc)

- Alarm display	
- Alarm history display	
- Clock function	
- Cycle start / Feed hold	
- Display of PMC alarm message	Message display when PMC alarm occurred
- Dry run	
- Ethernet function (Embedded)	
- External data input	
- Graphic display	Tool path drawing
- Help function	
- MDI / DISPLAY unit	10.4" color LCD, Keyboard for data input, soft-keys
- Memory card interface	
- Multi language display	
- Operation functions	Tape / Memory / MDI / Manual
- Operation history display	
- Program restart	
- Run hour and part number display	
- Search function	Sequence NO. / Program NO.
- Self - diagnostic function	
- Servo setting screen	
- Single block	

Optional Functions

- 3-dimensional coordinate conversion	
- 3-dimensional tool compensation	
- 3rd / 4th reference return	
- Addition of tool pairs for tool life management	1024 pairs
- Additional controlled axes	max. 6 axes in total
- Additional work coordinate system	G54.1 P1 - 300 (300 pairs)
- AI Contour Control II	600 block preview
- Automatic corner override	G62
- Chopping function	G81.1
- Cylindrical interpolation	G07.1
- Data server	
- Dynamic graphic display	Machining profile drawing
- Exponential interpolation	
- EZ Guide i (Doosan Infracore Conversational Programming Solution) with 10.4" Color TFT	
- Figure copying	G72.1, G72.2
- Handle interruption	
- High speed skip function	
- Increment system 1/10	
- Interpolation type pitch error compensation	
- Involute interpolation	G02.2, G03.2
- Machining time stamp function	
- Manual handle feed 2/3 unit	
- No. of Registered programs	1000 / 2000 / 4000 ea
- Number of tool offsets	400 / 499 / 999 / 2000 ea
- Optional block skip	addition 9 blocks
- Part program storage	512kb (1280m) / 1mb (2560m) / 2mb (5120m) / 4mb(10240m) / 8mb (20480m)
- Playback function	
- Polar coordinate command	G15 / G16
- Position switch	
- Programmable mirror image	G50.1 / G51.1
- Single direction positioning	G60
- Stored stroke check 2 / 3	
- Tape format for FS15	
- Tool offset	G45 - G48

**FANUC
32i**

Control Axes

- Controlled axes	5 (X, Y, Z, W, B)
- Simultaneous controlled axes	Positioning(G00) /Linear interpolation (G01) : 3 axes Circular interpolation (G02, G03) : 2 axes
- Backlash compensation	
- Emergency stop / overtravel	
- Follow up	
- Least command increment	0.001mm / 0.0001(inch)
- Least input increment	0.001mm / 0.0001(inch)
- Machine lock	all axes / Z axis
- Stored pitch error compensation	Pitch error offset compensation for each axis
- Stored stroke check 1	Overtravel controlled by software

Interpolation & Feed Function

- 2nd reference point return	G30
- Automatic corner deceleration	
- Circular interpolation	G02, G03
- Dwell	G04
- Feed per minute	mm/min(ipm)
- Feedrate clamp by circular radius	
- Feedrate override (10% increments)	0 - 200%
- Helical interpolation	
- Jog feedrate	0 - 5000 mm/min
- Linear ACC/DEC before interpolation	
- Linear interpolation	G01
- Manual handle feedrate	0.1/0.01/0.001mm
- NANO AICC (AI Contour Control)	200 block preview
- Override cancel	M48 / M49
- Positioning	G00
- Program restart	
- Rapid traverse override	F0 (fine feed), 25 / 50 / 100 %
- Reference point return	G27, G28, G29
- Skip function	G31
- Thread cutting, synchronous cutting	

Spindle & M-code Function

- M- code function	M 3 digits
- Polar coordinate interpolation	G12.1 / G13.1
- Rigid tapping	G84, G74
- Scaling	
- Spindle orientation	
- Spindle serial output	
- Spindle speed command	S5 digits
- Spindle speed override	10 - 150%

Programming & Editing Function

- Additional work coordinate system (48 Pair)	G54.1 P1 - 48 pairs
- Auto. Coordinate system setting	
- Background editing	
- Canned cycle	G73, G74, G76, G80 - G89, G99
- Circular interpolation by radius programming	
- Coordinate system rotation	G68, G69
- Custom macro B	
- Custom size	512kb
- I / O interface	USB/RS-232C
- Inch / metric conversion (G20 / G21
- Local / Machine coordinate system	G52 / G53
- Macro executor	
- Maximum commandable value	±99999.999mm (±9999.9999 inch)

- No. of Registered programs	500 ea
- Optional block skip	
- Optional stop	M01
- Part program storage	256kb (640m)
- Program number	O4-digits
- Program protect	
- Program stop / end	M00 / M02, M30
- Programmable data input	Tool offset and work offset are entered by G10, G11
- Sub program	Up to 4 nesting
- Tape code	ISO / EIA Automatic discrimination
- Work coordinate system	G54 - G59

Others Function (Operation, Setting & Display, etc)

- Alarm display	
- Cycle start / Feed hold	
- Display of PMC alarm message	Message display when PMC alarm occurred
- Dry run	
- Ethernet function (Embedded)	
- External data input	
- Graphic display	Tool path drawing
- Help function	
- MDI / DISPLAY unit	10.4" color LCD, Keyboard for data input, soft-keys
- Memory card interface	
- Multi language display	
- Operation functions	Tape / Memory / MDI / Manual
- Program restart	
- Search function	Sequence NO. / Program NO.
- Servo setting screen	

Optional Functions

- 3rd / 4th reference return	
- Addition of tool pairs for tool life management	512 pairs
- Additional controlled axes	max. 6 axes in total
- Additional work coordinate system	G54.1 P1 - 300 (300 pairs)
- AI HPCC* (High Precision Contour Control) with 64 bit Risc	600 block preview
- Automatic corner override	G62
- Chopping function	G81.1
- Cylindrical interpolation	G07.1
- EZ Guide i	(Doosan infracore Conversational Programming Solution) with 10.4" Color TFT
- Handle interruption	
- High speed skip function	
- Increment system 1/10	
- Interpolation type pitch error compensation	
- Manual handle feed 2/3 unit	
- Machining time stamp function	
- No. of Registered programs	1000 ea
- Number of tool offsets	400 ea
- Optional block skip addition	9 blocks
- Part program storage	512kb(1280m)/1mb(2560m)
- Polar coordinate command	G15 / G16
- Position switch	
- Stored stroke check 2 / 3	
- Programmable mirror image	G50.1 / G51.1
- Tool position offset	G45 - G48

DOOSAN FANUC i series

Basic Information

Diverse Line-up
High-Rigidity &
High-Precision
User Convenience

Detailed Information

Options
Capacity Diagram
Specifications

Customer Support Service

Control Axes

- Controlled axes	5 (X, Y, Z, W, B)
- Simultaneously controllable axes	Positioning(G00)/Linear interpolation(G01) : 3 axes Circular interpolation(G02, G03) : 2 axes
- Backlash compensation	
- Emergency stop / overtravel	
- Follow up	
- Least command increment	0.001mm (0.0001 inch)
- Least input increment	0.001mm (0.0001 inch)
- Machine lock	all axes / Z axis
- Mirror image	Reverse axis movement (setting screen and M-function)
- Stored pitch error compensation	Pitch error offset compensation for each axis
- Stored stroke check 1 Overtravel controlled by software	

Interpolation & Feed Function

- 2nd reference point return	G30
- Circular interpolation	G2, G3
- Cylindrical interpolation	G07.1
- Dwell	G4
- Exact stop check	G09, G61 (mode)
- Feed per minute (mm/min)	
- Feedrate override	0 - 200 %
- Helical interpolation	
- Jog override	0 - 200 %
- Linear interpolation	G01
- Manual handle feed 1 unit	
- Manual handle feedrate	0.1 / 0.01 / 0.001 mm
- override cancel	M48 / M49
- Positioning (G00
- Rapid traverse override	F0 (fine feed), 25 / 50 / 100 %
- Reference point return	G27, G28, G29
- Skip function	G31

Operation, Setting & Display, etc

- 3rd / 4th reference return	
- Additional work coordinate system	G54.1 P1 - 48 (48 pairs)
- AICC1 (AI Contour Control 1) with Hardware : 40 block preview	
- Alarm display	
- Alarm history display	
- Automatic corner override G62	
- Clock function	
- coordinate rotation	G68, G69
- Cycle start / Feed hold	
- display of PMC Alarm message	Message display when PMC alarm occurred
- Machine condition selection function	
- Embedded ethernet	
- Dry run	
- Graphic display	Tool path drawing
- Help function	
- High speed Skip function	
- MDI / display unit	10.4" color LCD, Keyboard for data input, 'soft-keys
- Memory card interface	
- Operation functions	Tape / Memory / MDI / Manual
- Operation history display	
- Optional angle chamfering / corner R	
- Polar coordinate command	G15 / G16
- program restart	
- Programmable data input	
- Tool offset and work offset are entered by	G10, G11
- Programmable Mirror image	G50.1 / G51.1
- run hour and Part number display	
- Scaling	G50, G51

- Search function	Sequence No. / program No.
- Self - diagnostic function	
- Servo setting screen	
- Single block	
- Single direction Positioning	G60
- Stored stroke check 2	

Spindle & M-code Function

- M - code function	M 3 digits
- Spindle orientation	
- Spindle serial output	
- Spindle speed command	S5 digits
- Spindle speed override	10 - 150 %

Tool Function

- Tool nose radius compensation	G40, G41, G42
- Number of tool offsets	400 ea
- Tool length compensation	G43, G44, G49
- Tool life management	
- Tool number command	T2 digits
- Tool offset memory C	Geometry / Wear and Length / Radius offset memory
- Tool Position offset	G45 - G48

Programming & Editing Function

- Absolute / Incremental programming	G90/G91
- Automatic coordinate system setting	
- Background editing	
- Canned Cycle	G73, G74, G76, G80 - G89, G99
- Circular interpolation by radius Programming	
- Custom macro B	
- Addition of Custom macro common variables	(#100 - #199, #500 - #999)
- Decimal point input	
- Extended Part program editing	
- Reader / puncher interface	RS - 232C, USB
- Inch / metric conversion	G20 / G21
- Label Skip	
- Local / Machine coordinate system	G52 / G53
- Maximum commandable value	±99,999.999 mm (±9,999.9999 inch)
- No. of Registered programs	400 ea
- Optional block Skip	
- Optional stop	M1
- Part program storage	1280m [512 kB]
- Palyback	
- program number	04-digits
- program protect	
- Program stop / end	M00 / M02, M30
- Rigid tapping	G84, G74
- Sub program Up to 4 nesting	
- Tape code ISO / EIA Automatic discrimination	
- Thread cutting	
- Work coordinate system	G54 - G59

Optional Specifications

- Additional controlled axes, max. 6 axes in total	
- AICC II (AI Contour Control II)	200 block preview
- Fast data server	
- Fast ethernet	
- Dynamic graphic display (w/10.4" Color TFT LCD) Machining profile drawing	
- When the EZ Guide i is used, the Dynamic graphic display cannot application	
- EZ Guide i (Doosan infracore Conversational Programming Solution) with 10.4" Color TFT	
- Dynamic graphic display Machining profile drawing	

**HEIDENHAIN
iTNC 530**

Control Axes

- Controlled axes 5 (X, Y, Z, W, B)
- Simultaneous controlled axes
Positioning / Linear interpolation 5 axes
Circular interpolation 2 axes
Helical interpolation 3 axes
- Backlash compensation
- Least command increment 0.001mm / 0.0001 (inch)
- Least input increment 0.001mm / 0.0001 (inch)
- Linear axis error compensation
- Reversal peaks with circular movement compensation
- Stick-slip friction compensation

Interpolation & Feed Function

- Circle In 3 axes
- Feedforward
- Feedrate override 0 -150 %
- Feed hold std.
- Helix interpolation
- Manual handwheel feed 1 unit
- Optional block skip
- Single block
- Spline interpolation
- Straight line In 5 axes

SPINDLE FUNCTION

- Spindle orientation
- Spindle position control
- Spindle speed override 0 - 150%

Tool Function

- 3 dimensional tool compensation
- Number of tool offset 999 ea
- Tool management

Spindle & M-code Function

- Actual position capture
- Calculator

- Comment and structure blocks in the NC program
- Complete list of all current error messages
- Context-sensitive help function for error message
- Datum tables
- Graphical support for programming cycles
- Graphic simulation
- Heidenhain conversation format programmi
- Mathematical function
- No. of registered program No limit
- Plane view
- Programming graphics
- Programming with variable Q parameters
- Program memory Approx 26GB on hard disk
- Returning to the contour
- The integrated help system TNC guide

Others Function (Operation, Setting & Display, etc)

- Actual speed display
- Alarm display
- Clock function
- Diagnostic function
- Display TFT 15" color
- Ethernet TCP / IP
- Integrated oscilloscope
- Log(error message and keystroke) use PCs
- Trace function
- USB USB1.1

Optional Specifications

- Display TFT 15" color
- DCM Collision
- DXF Converter
- Heidenhain DNC
- KinematicsOpt
- Tool touch probes TT-series, TL Series
- Workpiece touch probes TS-series

★ FOR A HEIDENHAIN NC, PLEASE CONTACT US.

Responding to Customers Anytime, Anywhere

Basic Information

Diverse Line-up
High-Rigidity &
High-Precision
User Convenience

Detailed
Information

Options
Capacity Diagram
Specifications

Customer Support
Service

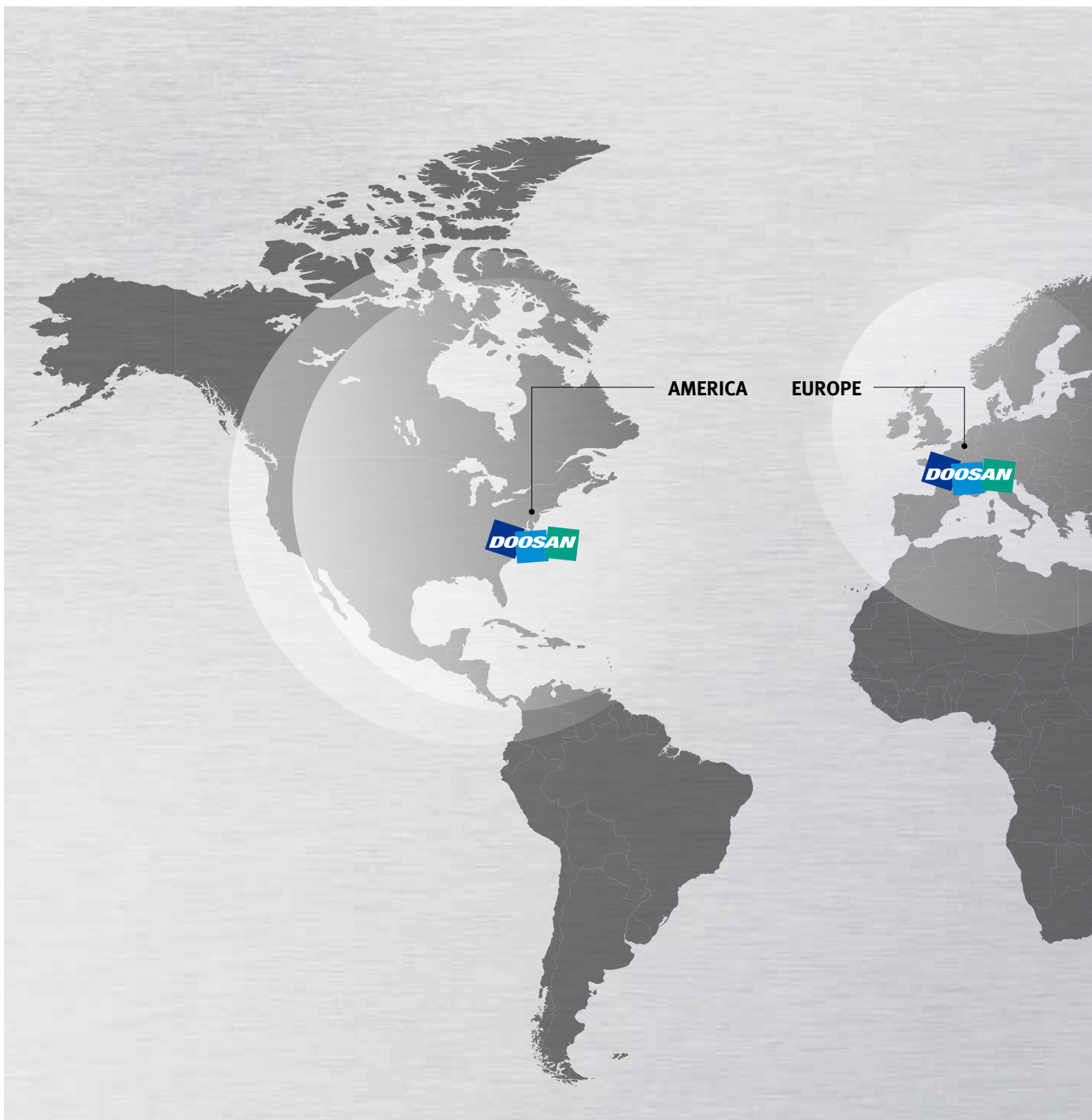

Global Service Support Network

Corporations

5

Dealer Networks

122

Technical Centers

18

Factories

3

Technical Center: Sales Support, Service Support, Parts Support

Doosan Machine Tools' Global Network, Responding to Customer's Needs nearby, Anytime, Anywhere

Doosan machine tools provides a system-based professional support service before and after the machine tool sale by responding quickly and efficiently to customers' demands. By supplying spare parts, product training, field service and technical support, we can provide top class support to our customers around the world.



Domestic Service Support Network

Integrated Support Centers	2	Sales Branch Offices	7	Post-Sales Service Centers	6	Designated Repair Service Centers	31
----------------------------	---	----------------------	---	----------------------------	---	-----------------------------------	----

Customer Support Service

We help customers to achieve success by providing a variety of professional services from pre-sales consultancy to post-sales support.

Supplying Parts



- Supplying a wide range of original Doosan spare parts
- Parts repair service

Field Services



- On site service
- Machine installation and testing
- Scheduled preventive maintenance
- Machine repair

Technical Support



- Supports machining methods and technology
- Responds to technical queries
- Provides technical consultancy

Training



- Programming / machine setup and operation
- Electrical and mechanical maintenance
- Applications engineering

DBC series



Model	X / Y / Z / W axes travel distance mm (inch)	Table size mm (inch)	Max. spindle speed r/min	Spindle motor kW (Hp)
DBC 110S	2000 / 1500 / 1200 / 500 (78.7 / 59.1 / 47.2 / 19.7)	1400 x 1600 (55.1 x 63.0)	3000	26 (34.9)
DBC 130S	2000 / 1500 / 1200 / 600 (78.7 / 59.1 / 47.2 / 23.6)	1400 x 1600 (55.1 x 63.0)	2500	30 (40.2)
DBC 130SL	2500 / 2000 / 1500 / 600 (98.4 / 78.7 / 59.1 / 23.6)	1400 x 1800 (55.1 x 70.9)	2500	30 (40.2)
DBC 110 II	2500 / 2000 / 1500 / 550 (98.4 / 78.7 / 59.1 / 21.7)	1400 x 1800 (55.1 x 70.9)	4000	26 (34.9)
DBC 130 II	3000 / 2000 / 1600 / 700 (118.1 / 78.7 / 63.0 / 27.6)	1600 x 1800 (63.0 x 70.9)	2500	26 (34.9)
DBC 130L II	4000 / 2500 / 2000 / 700 (157.5 / 98.4 / 78.7 / 27.6)	1600 x 1800 {1800 x 2000, 2000 x 2200} (63.0 x 70.9) {(70.9 x 78.7, 78.7 x 86.6)}	2500	26 (34.9)
DBC 250 II	3000 / 2000 / 1600 / 500 (118.1 / 78.7 / 63.0 / 19.7)	1600 x 1800 {1800 x 2000, 2000 x 2200} (63.0 x 70.9) {(70.9 x 78.7, 78.7 x 86.6)}	6000	30 (40.2)
DBC 250L II	4000 / 2500 / 2000 / 500 (157.5 / 98.4 / 78.7 / 19.7)	1600 x 1800 {1800 x 2000, 2000 x 2200} (63.0 x 70.9) {(70.9 x 78.7, 78.7 x 86.6)}	6000	30 (40.2)



Doosan Machine Tools

<http://www.doosanmachinetools.com>

www.facebook.com/doosanmachinetools

Optimal Solutions for the Future

Head Office

Yeonkang Bldg., 6th FL., 270, Yeonji-dong,
Jongno-gu, Seoul, Korea
Tel +82-2-3670-5345 / 5362
Fax +82-2-3670-5382

Doosan Machine Tools China

Room 101,201,301, Building 39 Xinzhuan Highway
No.258 Songjiang District,China Shanghai(201612)
Tel +86 21-5445-1155
Fax +86 21-6405-1472

Doosan Machine Tools Japan

#2412, Mita Kokusai Bldg. 1-4-28 Mita,
Minato-ku, Tokyo 108-0073, Japan
Tel +81 3 5730 9013
Fax +81 3 5730 9016

Doosan Machine Tools America

19A Chapin Rd., Pine Brook, NJ 07058, U.S.A.
Tel +1-973-618-2500
Fax +1-973-618-2501

Doosan Machine Tools Europe

Emdener Strasse 24, D-41540 Dormagen, Germany
Tel +49-2133-5067-100
Fax +49-2133-5067-111

Doosan Machine Tools India

106 / 10-11-12, Amruthahalli, Byatarayanapura,
Bellary road, Bangalore-560 092, India
Tel +91-80-4266-0122 / 121 / 100



* For more details, please contact Doosan Machine Tools.
 * The specifications and information above-mentioned may be changed without prior notice.
 * Doosan Machine Tools Co., Ltd. is a subsidiary of MBK Partners. The trademark  **DOOSAN** is used under a licensing agreement with Doosan Corporation, the registered trademark holder.